

ELECRAFT W1 Power Meter

Assembly and Operating Manual

E740100: Revision D, June 25, 2009
Copyright © 2009, Elecraft; All Rights Reserved

Introduction

The Elecraft W1 is a versatile RF power and SWR meter that can be used with any transmitter from QRP levels to 140 watts output from 1.8 to 30 MHz. The W1 automatically selects the proper power range of up to 1.4, 14 or 140 watts and indicates the peak forward power and SWR on built in LEDs. The power and SWR is also available through a connector as RS232 serial data for display on a computer or to control other equipment.

The W1 Power meter is designed to be used as a stand-alone unit that may be powered from a self-contained battery or an external power source. Optionally, it may be built into existing equipment or an enclosure of your choice. See Assembly Options on page 3 for more information.

The W1 uses no surface-mount technology, so it's an ideal project for first-time builders.

Specifications

Size: 5-3/8" x 2-11/16" (13.7 cm x 6.8 cm).

Internal Power: 9V battery.

External Power: 7-14 V (8 V min. recommended).

Current Drain: 10 mA idle, 30 mA with 10 LEDs illuminated.

Power Range: Auto-ranging, 1.4, 14 and 140 watts.

Accuracy: 0.5 dB typical.

Frequency Range: 1.8 to 30 MHz.

Tools Required

You will need the following tools to build this kit:

- Fine-tip temperature-controlled ESD-safe soldering station with 700 to 800°F tip (370-430°C). Recommend a spade tip no greater than 0.05" (1.3 mm) wide.
- IC-grade solder (Kester #44 or equivalent). Small diameter solder (e.g. .031") is easiest to work with on small printed circuit boards. **DO NOT use acid-core solder, water-soluble flux solder, additional flux or solvents.**
- Needle-nose pliers.
- Diagonal cutters.
- Small, #2 Phillips screwdriver.
- Small wrench or driver for 4-40 nut.
- Digital Multimeter (DMM) with voltage, resistance and diode-checking functions is useful for confirming the value of components. A DMM with capacitance measurement capability is desirable, but not required.
- Desoldering tools and supplies are invaluable. Narrow solder wick or a good vacuum desoldering tool such as the Soldapullt® model DS017LS are recommended.
- A conductive wrist strap and anti-static mat is recommended (see *ESD-Sensitive Parts* below). Wrist straps and mats are available at very low cost from Jameco, Mouser, and other electronics suppliers.

Refer to www.elecraft.com for tool sources and solder recommendations.

Parts List

We strongly recommend that you do a complete inventory before beginning assembly. The inventory helps you correctly identify all the parts to avoid mistakes during assembly.

ESD-Sensitive Parts

Some of the parts in this kit are sensitive to damage from electro-static discharge (ESD). Problems caused by ESD damage may be very difficult to troubleshoot because damaged components may still operate somewhat rather than fail completely. We strongly recommend you take the following anti-static precautions (listed in order of importance) to avoid trouble:



- Leave ESD-sensitive parts in their anti-static packaging until you install them. The packaging may be a special plastic bag or the component's leads may be inserted in conductive foam. Parts which are especially ESD-sensitive are identified in the parts list and in the assembly procedures.
- Wear a conductive wrist strap with a series 1 megohm resistor. If you do not have a wrist strap, touch a ground briefly before touching any sensitive parts to discharge your body. Do this frequently while you are working. You can collect a destructive static charge on your body just sitting at the work bench. **DO NOT attach a ground directly to yourself as this poses a serious shock hazard.**
- Make sure your soldering iron is ESD-safe and has a grounded tip
- Use a grounded anti-static mat on your work bench.

Identifying Parts

In some cases the component marking is self-evident. For example, a 1N5711 diode may have "1N5711" stamped on its body. When the markings are not so obvious, the marks you should find to identify individual components are shown in parenthesis in the parts list and text. These may be numbers such as "(103)" on capacitors or colors on resistors such as "(brn-blk-red)". Look for the color band sequence starting near one end of the component. Some resistors have dark blue bodies that make identifying the colors difficult. Use your DMM to verify the value if you aren't sure. Remember that your DMM usually will indicate a value close to, but not exactly what is shown due to normal tolerances in the components and the DMM.

There may be more numbers, letters or color bands on a component than those shown in parenthesis. The additional markings may change from unit to unit and are not important for identifying the part supplied with the kit.

Reference Designator	Description	Qty	Part Number
Misc.	W1 Power Meter Printed Circuit Board	1	E100308
B1	Battery Holder	1	E980074
C1, C2	.001 μ F (102) Capacitor	2	E530074
C3, C10	.047 μ F (473) Capacitor	2	E530131
C4, C5, C6, C7, C11, C12, C16, C17	.01 μ F (103) Capacitor	8	E530130
C8, C9	22 μ F 25V Electrolytic Capacitor	2	E530012
D1, D2, D3	1N5711 (5711) Diode	3	E560004
D4, D5, D29	1N4148 (4148) Diode	3	E560002
D6, D7, D8, D9, D10, D11, D12, D13, D14, D15, D16, D17, D18, D19, D20, D21, D22, D23, D24, D25	Rectangular LED, Red	20	E570026
D26	Round LED, Green	1	E570027
D27	Round LED, Yellow	1	E570028
D28	Round LED, Red	1	E570025
J1, J2	BNC Connector, PC Mount	2	E620020
J3	Stereo Jack, Miniature	1	E620027
J4	Jack, 2.1 mm, 12VDC Power	1	E620026
R1, R2	51 Ω 3W Resistor	2	E500178
R3, R4, R5	332K, 1% (org-org-red-org) 1/4W Resistor	3	E500254
R6, R7, R9	49.9K 1% (yel-wht-wht-red) 1/4W Resistor	3	E500255
R8	47K (yel-vio-org)1/4W Resistor	1	E500067
R10	240 Ω (red-yel-brn) 1/4W Resistor	1	E500281
R11	2K (red-blk-red) 1/4W Resistor	1	E500280
R12, R13, R20	24.9K 1% (red-yel-wht-red)1/4W Resistor	3	E500120
R14	1K (brn-blk-red) 1/4W Resistor	1	E500013

Reference. Designator	Description	Qty	Part Number
R15, R21	100K (brn-blk-yel) 1/4W Resistor	2	E500006
R16	10k (brn-blk-org) 1/4W Resistor	1	E500015
R17	5k (502) Trimmer Potentiometer	1	E520009
R18, R22	22K (red-red-org) 1/4W Resistor	2	E500090
R19	3K (org-blk-red) 1/4W Resistor	1	E500169
RP1, RP2	2K (202P) Resistor pack	2	E510031
Q1, Q2, Q3, Q4, Q5, Q6	2N7000 Transistor  ESD Sensitive. Take precautions when handling (see ESD-Sensitive Parts above.)	6	E580002
Q7	2N3904 Transistor	1	E580017
SW1	Switch	1	E640009
T1	Binocular Core	1	E690011
U1, U2	LMC6482 Integrated Circuit  ESD Sensitive. Take precautions when handling (see ESD-Sensitive Parts above.)	2	E600011
U3	LM78L05 Integrated Circuit	1	E600029
U4	Microcontroller PIC16F876A, Programmed  ESD Sensitive. Take precautions when handling (see ESD-Sensitive Parts above.)	1	E610022
X1	Ceramic Resonator, 4MHz (4.00)	1	E660001
Hardware	Screw, Pan Head, Black Machine, 4-40	4	E700008
Hardware	Lock Washer, Internal Tooth, #4	4	E700010
Hardware	Nut, #4-40	4	E700011
Misc.	I.C. Socket, 28 Pin	1	E620011
Misc.	#28 Enameled Wire for T1	72"	E760003
Misc.	#18 Teflon ¹ Insulated Wire for T1	6"	E760021
Misc.	Rubber Foot	4	E700024

Assembly Options

The W1 is designed to operate as a stand-alone unit without an enclosure. Several options are provided in case you want to build the unit into an enclosure or existing equipment:

1. Your W1 is provided with BNC connectors that mount parallel to the board. Normally these connectors will be mounted on the top (silk screened) side of the board so that the board rests flat on the supplied rubber feet attached to the bottom. However if you are building the unit to place in an enclosure of your choice, you may elect to mount the BNC connectors on the bottom of the board. Also, you may purchase right-angle BNC connectors that also may be mounted either on the top or the bottom of the board. Suitable connectors are available from Digi-Key[®] (www.digikey.com, part number A32246-ND) or Mouser Electronics[®] (www.mouser.com, part number 571-2272226).
2. Mounting holes are provided in the board that you may use with your own #4 hardware and spacers as desired instead of using the rubber feet.
3. If you are going to power your W1 using an external source only, you may choose not to install the battery holder.
4. Transformer T1 may be obtained pre-wound from an Elecraft-approved source. See www.elecraft.com for details.

¹ Teflon is a registered trademark of du Pont de Nemours and Company.

Assembly Procedure

The finished Power Meter is shown in Figure 1. We recommend you follow the assembly procedure below and refer to this figure as needed.

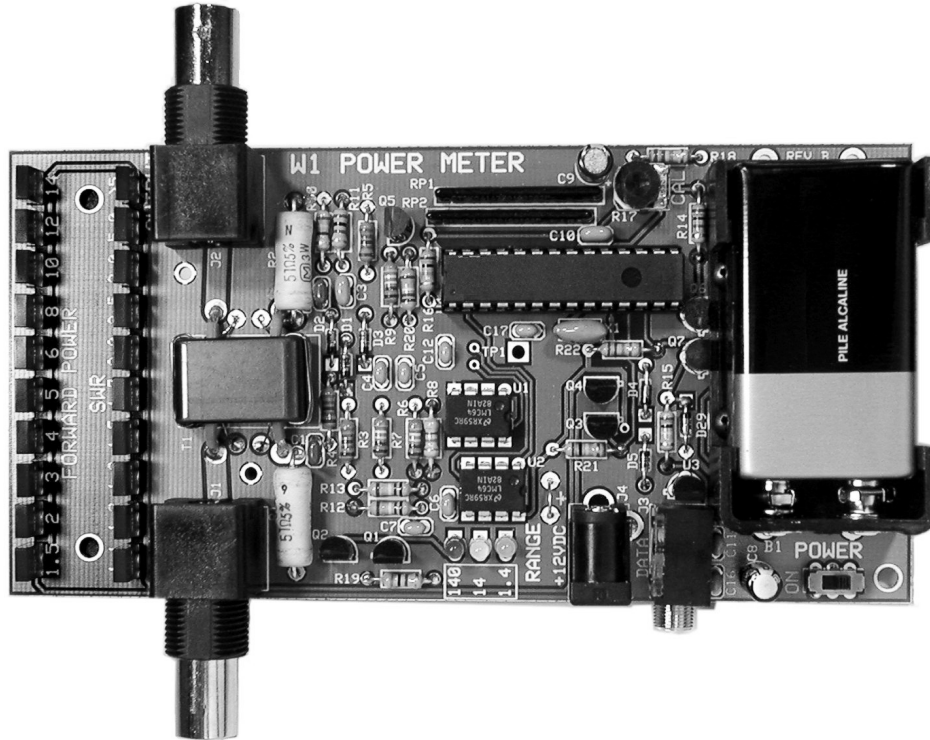

Figure 1. Assembled W1 Power Meter.



Use adequate ventilation when soldering; avoid inhaling smoke or fumes. Always wash your hands after handling solder, as lead residue is highly toxic.

When applying solder, use the *minimum* amount required to surround the component lead and make good contact with its printed-circuit pad. You don't need a "fillet" (build-up) of solder. This will avoid unwanted solder bridges and any need to clean the PC boards.

The solder must flow onto both the component lead and its PC board pad. To ensure that both will be heated at the same time, the tip of the iron should contact both the component lead and the PC board pad before solder is applied.

Solder joints should be *clean* and *shiny*. If a joint appears dull or has fine cracks, it is probably cold. Cold solder joints should be cleaned and re-soldered. First, use solder wick (desoldering braid) to remove the old solder. Then apply fresh solder. If you have many cold solder joints, it probably indicates that your soldering iron temperature is too low, or that the tip or solder itself is defective.

Install the fixed resistors listed below. Position each resistor against the board within the outline, solder and trim the leads flush on the bottom. If you position the board so the legends are right side up, you can work clockwise around the board starting with R10 near the space for R2 at the top (Resistors R1 and R2 will be installed later). ***Save one of the clipped resistor leads to use for a ground test point later.***

- | | | |
|------------------------------------|---------------|-----------------------------------|
| __ R10, 240 Ω (red-yel-brn) | \Rightarrow | __ R11, 2K (red-blk-red) |
| __ R5, 332K 1% (org-org-red-org) | \Rightarrow | __ R9, 49.9K 1% (yel-wht-wht-red) |
| Continued on next page. | | |
| __ R20, 24.9K 1% (red-yel-wht-red) | \Rightarrow | __ R16, 10K (brn-blk-org) |

__ R18, 22K (red-red-org)	⇒	__ R14, 1K (brn-blk-red)
__ R22, 22K (red-red-org)	⇒	__ R15, 100K (brn-blk-yel)
__ R21, 100K (brn-blk-yel)	⇒	__ R8, 47K (yel-vio-org)
__ R6, 49.9K 1% (yel-wht-wht-red)	⇒	__ R19, 3K (org-blk-red)
__ R12, 24.9K 1% (red-yel-wht-red)	⇒	__ R13, 24.9K 1% (red-yel-wht-red)
__ R7, 49.9K 1% (yel-wht-wht-red)	⇒	__ R3, 332K 1% (org-org-red-org)
__ R4, 332K 1% (org-org-red-org)		Be careful not to fill the solder pad for D2.

Install the resistor packs (RP) near the top center of the board. The numbers indicating the value shown below are normally the last of a long series of letters and digits. Orient each resistor pack so the grey dot near one end is closest to the square solder pad. Be sure the packs are positioned vertically with respect to the board and that all the pins are soldered.

__ RP1, (202P)	⇒	__ RP2, (202P)
----------------	---	----------------

Locate the six small glass diodes. If you haven't done so already, sort them by type. Use a strong magnifier, if necessary, to identify the diodes by the lettering on their bodies. There are three type 1N5711 and three type 1N4148. Frequently the "1N" part of the type number is not shown on the diode and the remaining numbers and letters may be broken into two lines.

Install the diodes as follows. The black end of the diode body must be aligned with the stripe on the silk screened outline on the board and closest to the square solder pad.

__ D2, 1N5711 (5711) near R4	⇒	__ D1, 1N5711 (5711)
__ D3, 1N5711 (5711)	⇒	__ D4, 1N4148 (4148) near R22
__ D5, 1N4148 (4148)	⇒	__ D29, 1N4148 (4148)

Install the capacitors listed below, working from left to right across the board:

__ C2, .001μF (102) near D2	⇒	__ C1, .001μF (102) below C2 near R4
__ C3, .047μF (473) next to C2	⇒	__ C4, .01μF (103)
__ C5, .01μF (103)	⇒	__ C7, .01μF (103)
__ C6, .01μF (103)	⇒	__ C12, .01μF (103)
__ C17, .01μF (103)	⇒	__ C10, .047μF (473) near RP2
__ C11, .01μF (103) lower edge below D29	⇒	__ C16, .01μF (103)



Once soldered, the socket for U4 will be difficult to remove from the board without destroying it. Before soldering, check to be certain it is positioned correctly.

Align the socket with the outline for U4 just below resistor packs RP1 and RP2. **Be sure the notched end of the socket is aligned with the notch in the silk-screened outline on the board at the end closest to R16.** While holding the socket against the board, wet your soldering iron with a small drop of solder and touch it to one pin at each end of the socket to hold it in place, then inspect the socket carefully to ensure that the shoulders of all the pins are against the top of the board. If needed, reheat the soldered pins while pressing the down on the socket.

When you are satisfied that the socket is seated against the top of the board, solder all 28 pins. Be sure to properly solder the pins you temporarily soldered in the preceding step.

Install ceramic resonator X1 (4.00) near the socket for U4. It looks like a large molded capacitor but has three pins. It may be installed oriented either way.

Bend the clipped resistor lead you saved earlier into a "U" that fits into the solder pads at each end of the ground test point below R21. The solder pads have a line between them and a $\frac{1}{2}$ symbol next to the line. Solder the lead into the pads with the loop high enough above the board to easily clip a test probe lead onto it.

Position trimmer potentiometer R17 (502) on the board over the silk screened outline near RP1 and RP2 with the beveled end lined up over the beveled end of the outline. Press down until the three pins snap into the solder pads up to the shoulders on the pins. When properly positioned, base of the pot will stand about 1/8" (3mm) above the board. Solder all three pins.

Inspect the leads of one of the electrolytic capacitors. Note that there is a stripe with a – on the body to identify the negative lead. **The negative lead must be inserted in the round solder pad on the board.** The positive lead must be inserted in the square solder pad. There is a + symbol near that pad. The positive lead is slightly longer on most capacitors. Install the electrolytic capacitors as follows:

__ C9, 22 μ F (near pot R17 at the top) \Rightarrow __ C8, 22 μ F (near lower right corner)

Install slide switch SW1. SW1 does not appear on the board. The switch location is marked POWER. Fit the six pins through the six holes. The switch can be oriented either way. Solder one pin and make sure it is resting squarely against the shoulders on all six pins. If necessary reheat the soldered pin while pressing down on the switch until it is fully seated. Solder all six pins.

Wind the two 10-turn secondaries on the binocular core for transformer T1 as follows²:

- Cut two 22-inch (56 cm) lengths of the #28 enameled wire.
- Wind each length through one side of the binocular core as shown in Figure 2. The wire passes through the hole in the core exactly 10 times (and passes down the side of the core 9 times), so turn 1 is when you first slip the wire through the hole, before you wrap it around the outside.
- Tin all four leads up to about 1/8" (6 mm) of the core using **one** of the following techniques:
 1. Heat stripping: Melt a blob of solder on the tip of your iron and insert the clipped end of the lead in the blob. The insulation will bubble and vaporize after about 5 seconds. Add solder and feed the wire into the blob up to the edge of the core, then slowly pull the wire out of the solder. If any enamel remains on the lead, scrape it away.
 2. Burn the insulation off by heating it with a butane lighter for a few seconds. Remove any residue with sandpaper, then tin the bare wire.
 3. Scrape the wire with a sharp tool. Take care not to nick the wire. Remove all the insulation around the entire circumference of the wire, then tin the wire.

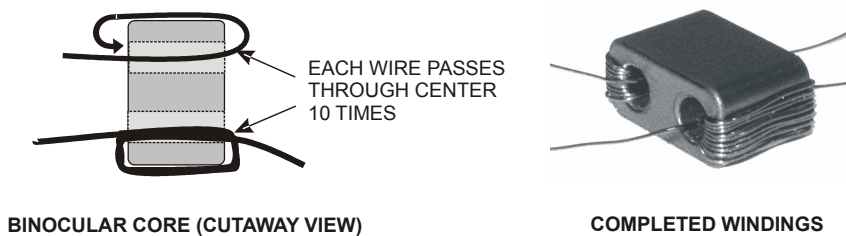

Figure 2. Winding T1 Secondaries.

Cut two 1-1/2" (3.8 cm) lengths of the #18 insulated wire. Strip 3/8" (9mm) of the insulation from each end, leaving 3/4" (19mm) of insulation covering the center section of each wire. Very lightly tin each wire to keep the strands from separating.

² A pre-wound transformer is available from an Elecraft-approved source. See www.elecraft.com for details

Refer to Figure 3. T1 fits over the outline on the board, between the outlines for resistors R1 and R2 and the INPUT and OUTPUT jacks J1 and J2. Slip one prepared length of #18 wire through each opening in the binocular core and bend the ends so the ends of one wire goes into the large solder pads on the traces leading to J1 and J2 and the ends of the other wire go to the large solder pads on the traces next the outlines for resistors R1 and R2.

Pull the #18 wires through the board and bend them over to hold the binocular core in place, then solder them to the pads.

Solder the secondary windings of T1 to the remaining solder pads. Each winding connects to the solder pad on either end of the core closest to the winding. Be sure you have good electrical contact when soldering. Do not pull the wire through the board so far that you no longer have the tinned wire inside the solder pad. You should see clean, tinned wire above the pad as shown in Figure 3.

Install resistor R2, 3-watt 51-ohm (51Ω), spaced just above the board to allow air to circulate (see Figure 4):

- Bend the leads to fit the solder pads on the board. R2 is located directly above T1.
- Place the resistor on the board, and bend the leads outward while holding the resistor slightly above the board. The stiff leads should hold the resistor in place.
- Solder one lead and check to be sure the resistor is still in place above the board, then solder the other lead.
- Trim the leads flush with the bottom of the board.

Install resistor R1, 3-watt 51-ohm (51Ω), spaced just above the board as you did with R2.

 **In the following steps, be certain the *long* lead of each LED goes into the *round* solder pad as you install them.**

The LEDs will not light if you install them backwards.

Locate the round, green LED D26. Note that one lead is slightly longer than the other. ***Insert the long lead in the lower, round solder pad*** next to the silk screened “1.4” near the bottom center of the board. The reference designator “D26” does not appear on the board. Bend the leads to hold the LED in place.

Solder one lead, then carefully adjust the position of the LED as needed so it is sitting vertically with respect to the board.

When you are satisfied with the position of the LED, solder the second lead and trim both leads flush with the bottom of the board.

Follow the same procedure to install the round LEDs D27, yellow, and D28, red:

__ D27, yellow, next to “14” on the board ⇒ __ D28, red, next to “140” on the board

Install the red rectangular LEDs D6 through D25 on the board. Each LED is adjacent to the silk screened legend shown below. Be certain the ***long lead*** of each LED goes ***into the round solder pad***: Take care to position each LED is vertically on the board and aligned with the LEDs next to it to form straight rows. You can easily align the LEDs without special tools as follows:

1. Place the LED leads in the solder pad holes. Be sure the ***long*** lead goes into the ***round*** solder pad.
2. Hold the LED against the board with your finger. Rock it back and forth slightly and note that you can feel when it is sitting squarely on the PCB.

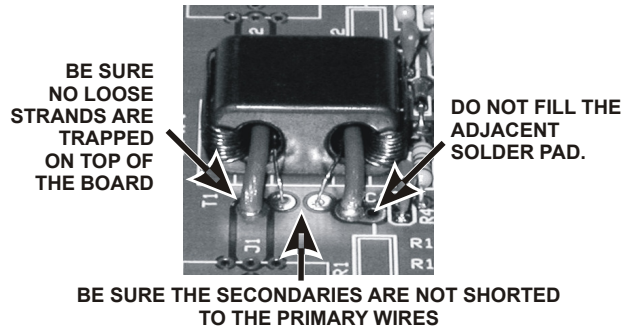
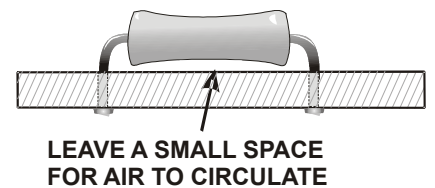

Figure 3. Mounting T1 on the PCB.



3. While holding the LED squarely on the PCB, wet the tip of your soldering iron with a small drop of solder and touch it to one lead and solder pad on the bottom of the board to hold it in place.
4. Be sure the LED is against the board and perpendicular to it, and forms a straight line with the adjacent LEDs. If needed, reheat the solder joint while straightening the LED.
5. When you are satisfied with the position of the LED, solder the other lead, then go back and properly solder the lead you tack-soldered in place. Trim both leads flush with the bottom of the board.

__ 1.1 ⇒ __ 1.2 ⇒ __ 1.3 ⇒ __ 1.5 ⇒ __ 1.7
 __ 2.0 ⇒ __ 2.5 ⇒ __ 3.0 ⇒ __ 5.0 ⇒ __ > 5
 __ 1.5 ⇒ __ 2 ⇒ __ 3 ⇒ __ 4 ⇒ __ 5
 __ 6 ⇒ __ 8 ⇒ __ 10 ⇒ __ 12 ⇒ __ 14

Install U3 and Q7 near the outline for battery pack BT1. **The flat side of the case must be aligned with the flat side of the silk screened outline on the board.** When in position, it should be perpendicular to the board and standing between 1/16" and 1/8" (1.7 and 3 mm) above the board.

__ U3, (LM78L05) ⇒ __ Q7 (2N3904). Take care not to install it in the space for Q6 by mistake.

Install stereo jack J3 over the outline for the DATA jack near U3. Be sure it is positioned against the board before soldering all the pins. **Do not apply heat longer than necessary. Excessive heat may damage the jack.** The usual problem with soldering jacks is that the soldering temperature is set too low and your iron can't deliver heat fast enough to the larger pins and solder pads.

Install power connector J4 next to J3. Be sure it is sitting square against the board before soldering all the pins.



Normally the battery holder will be installed on top of the board within the silk screened outline. However, if you are planning to use the W1 in an enclosure, you may mount it on the bottom of the board or leave it off entirely if the W1 will be powered only from an external source (see Assembly Options on page 3).

Install battery B1 holder as follows:

- Position the battery holder on the board within the outline. Be sure you have it on the correct side of the board. Unless you have a special need, you will want to put it on the top side along with the other components. **Do not solder yet.**
- Attach the holder to the board with the 4-40 screws in four places, using lock washers and nuts. The screw heads should be on the holder side so the battery will fit correctly. You may need to bend the battery holder terminals slightly to align the screw holes with those in the board.
- Solder the two terminals to the pads and trim them flush.



Normally the BNC jacks J2 and J2 will be installed on top of the board within the silk screened outline. However, if you are planning to use the W1 in an enclosure, you may mount them on the bottom of the board or use connectors that orient the jacks perpendicular to the board (see Assembly Options on page 3).

Install battery BNC jacks J1 and J2. Normally they will go on the same side of the board with all the other components positioned within the silk screened outlines. Note that there are extra ground solder pads provided for those who wish to mount the jacks differently for use in an enclosure.

__ J1 ⇒ __ J2



Follow ESD protection while handling the transistors and integrated circuits in the following steps (see ESD-

Sensitive Parts on page 2). Either wear a wrist strap or touch an unpainted ground regularly while working. Even after mounting the transistors on the board, they are still subject to ESD damage until U4 is installed in its socket.

Install the following transistors. **The flat side of the case must be aligned with the flat side of the silk screened outline on the board.** When in position, each transistor should be perpendicular to the board and standing between 1/16” and 1/8” (1.7 and 3 mm) above the board.

- | | | |
|--|---|---|
| __ Q5, 2N7000 near RP2 at top of board. | ⇒ | __ Q6, 2N7000 near Q7 and the battery holder. |
| __ Q4, 2N7000 near R22 at center of board. | ⇒ | __ Q3, 2N7000 next to Q4. |
| __ Q1, 2N7000 near R19 at bottom of board. | ⇒ | __ Q2, 2N7000 next to Q1. |

Install U1 (LMC6482) as follows:

- Place U1 on the board where shown by the outline near the center. If the pins are spread too wide to fit, place U1 on its side on a solid, flat surface and rock it gently to bend all the pins inward slightly as shown Figure 5. Do the same on both sides until it fits into the solder pads on the board.
- Align the end of U1 that has a notch or dimple molded in the case with the notch on the silk screened outline.
- Hold U1 in place, wet the tip of your soldering iron with solder and tack-solder one pin to hold it in place.
- Make sure U1 is correctly positioned and flat against the board, then solder the remaining pins.
- Reheat the tack-soldered pin as needed to ensure it is properly soldered.

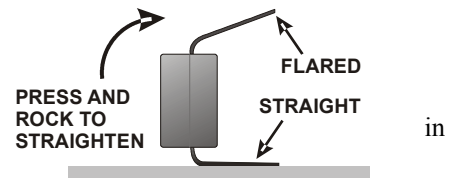

Figure 5. Straightening I.C.

Install U2 (LMC6482) using the same procedure you used for U1.

Inspect 28-pin controller U4 and identify the end that has a dimple or notch on the top. This end must be aligned with the notch in the socket when it is installed.

Test fit U4 in the socket and straighten leads as you did for the other ICs so they fit smoothly into the socket holes. Be especially careful that no pins become jammed underneath the IC. They can be very hard to see once it is installed.

When you are sure U4 is oriented with the dimpled end aligned with the notch and the pins are aligned with the socket holes, press down firmly on the MCU while checking the pins for any that fail to slide into the socket properly. Apply pressure alternately to one end and then to the other of the MCU as necessary to ensure the pins go all the way into the socket. Be especially careful that no pins miss the socket holes and become jammed underneath the IC. They can be very hard to see once U4 is seated.

Unless you are building the W1 into an enclosure, attach the four feet to the bottom of the board, near the corners. They will adhere best if you do not place them over occupied solder pads.

Checkout and Calibration

If you have difficulty with the following steps, refer to the circuit description and troubleshooting in the following sections.

With no battery installed or power connected to the W1, position the POWER switch ON and measure the resistance across the battery holder terminal or the +12VDC connector. Place the positive lead from your DMM on the + or center pin. If you are unsure about the polarity of your DMM, check it with your probes reversed. The resistance must be > 1 megohm. Your DMM may read “overrange” or infinity. Any reading that is not less than 1 megohm is fine.

- Turn the POWER switch OFF, then install a 9-volt battery in the holder or connect a d-c supply between 9 and 14VDC to J4 (positive to center pin).
- Turn the POWER switch ON. The FORWARD POWER LEDs should flash, then the SWR LEDs and finally the RANGE LEDs. The green 1.4 watt RANGE LED should then stay on, indicating the W1 is ready at the lowest power range.
- Connect your DMM negative probe to the ground test point between U2 and J4 and place the positive probe on TP1 near the center of the board. Adjust the CAL trimmer potentiometer for 4.50 VDC at TP1. This will calibrate your W1 to measure power quite accurately over its range. Typically the accuracy will be at least within 0.5 dB with each LED illuminating just as the indicated power level is reached. For example, the “5” LED will light just as the power reaches 0.5, 5 or 50 watts. The range is indicated on the three RANGE LEDs.



If you have an RF wattmeter that you are certain is more accurate than about 0.5 dB, you can use it to calibrate your W1 by monitoring the power and adjusting CAL so the readings match.

- Apply RF to the INPUT with a suitable load connected to the OUTPUT. The FORWARD POWER and RANGE lights will illuminate showing the RF power and the SWR lights will indicate the standing wave ratio. The FORWARD POWER and SWR displays are peak reading: they indicate the highest instantaneous power or SWR detected.

Serial Interface

In addition to the LED readout provided on the W1, data is also available in serial format at data jack J25. See Serial Interface Commands on page 14 for a complete list of the commands and responses.

Figure 6 shows the connections recommended to provide this data to a computer serial port. A kit of the parts needed to fabricate a 6-foot (1.8 meter) serial interface cable as shown below is available from Elecraft. Order W1SERKT.

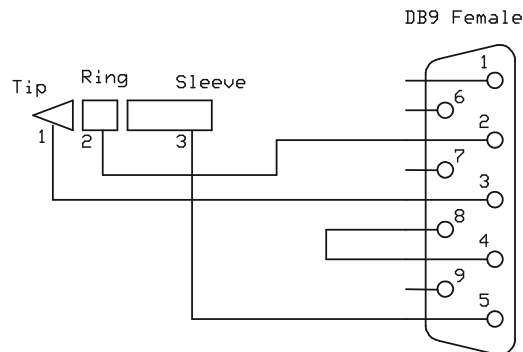

Figure 6. Serial Interface Cable Connections.

Troubleshooting

If the LEDs do not flash when the POWER is switched ON, check the orientation of diode D4 if using internal battery or D5 if using an external supply.

Most problems can be traced to the wrong component or a diode, electrolytic capacitor or integrated circuit installed backwards. If a specific LED fails to light, but the other LEDs associated with it do, the LED is probably defective or installed backwards. Another critical point to check are the secondary windings on T1. Be sure the leads are properly tinned. Reheat the leads where they enter the pads by touching your soldering iron to the tinned area of the wire near the solder pad. Often this will serve to create a good electrical contact with the wire by burning remaining enamel off the wire without overheating the solder pad.

Circuit Description

Refer to the schematic diagrams on pages 12 and 13 . Transformer T1 is a directional coupler sampling the forward and reflected power passing through J1 and J2. The forward RF power sample is terminated by resistor R1 and the reflected power is terminated by resistor R2. The coupler has about 20 dB of isolation, so at 140 watts either resistor may dissipate nearly 2 watts. For that reason 3 watt resistors are used and spaced slightly above the board for good air circulation.

A special RF detector circuit is used that has good accuracy over a much wider range of powers than that used in most power meters and SWR bridges. Diode D1 rectifies the forward power sample while D2 rectifies the reverse power sample. They are shunt rectifiers whose anodes are grounded by capacitor C3, so they develop a positive dc voltage output. To enhance the low power sensitivity, both diodes are forward biased from the +5V supply through resistor R11 and the 324K 1% resistors R3 and R4. About 1 microampere flows through the diodes even when no signal is present, overcoming the lack of sensitivity and linearity that normally is found when a diode is operated at very low voltages. However, diodes operated this way are very sensitive to ambient conditions, especially temperature. Diode D3 is included as a compensating diode. No RF is applied to D3, just the d-c bias from the +5V supply so its current is not affected by the RF applied to the coupler. The voltage D3 produces across R5 is subtracted from the voltages produced by D1 and D2 to compensate for any changes in the outputs of D1 and D2 caused by environmental conditions.

Operational amplifiers U1 and U2 sample the voltages and send the outputs of the diodes to controller U4 (sheet 2) which drives the Forward Power and SWR LEDs. The Forward Power and SWR LEDs are illuminated alternately by transistors Q3 and Q4. Signals from U4 turn on Q3 and Q4 alternately at a rate too fast to see by eye.

At high power levels RF detector diodes D1 and D2 would produce dc voltages too high for U4, so U4 provides a SCALE output to switch in fixed attenuators for D1, D2 and D3 by turning on Q1, Q2 and Q5 to ground R12, R13 and R20. U4 also drives LEDs D26, D27 or D28 to indicate that the Forward Power indicated is either 1.4 watts, 14 watts or 140 watts full scale.

Potentiometer R17 provides an adjustable bias for U4 that calibrates the Forward Power display.

Transistors Q6 and Q7 condition the signals being provided to and received from the serial data port J5.

Voltage regulator U3 provides a stable 5V output from either an internal 9V battery or an external 12V source. Diodes D4 and D5 isolate the two supply sources so the external supply won't force current into the battery and the battery won't be drained if a load is left attached to J4.

Schematic Diagram, Sheet 1

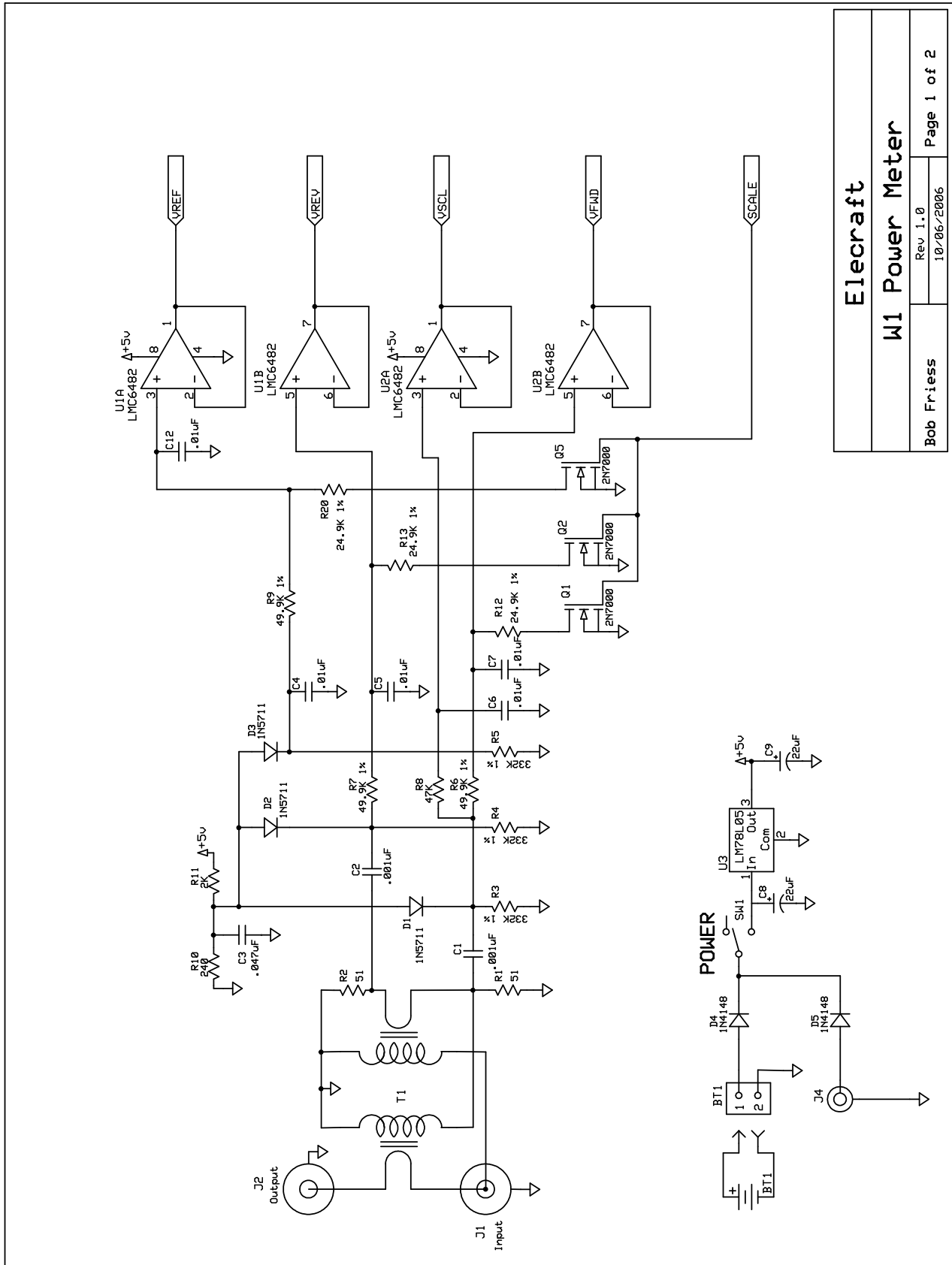

Elecraft	
W1 Power Meter	
Bob Fries	Page 1 of 2
Rev 1.0	10/06/2006

Schematic Diagram, Sheet 2

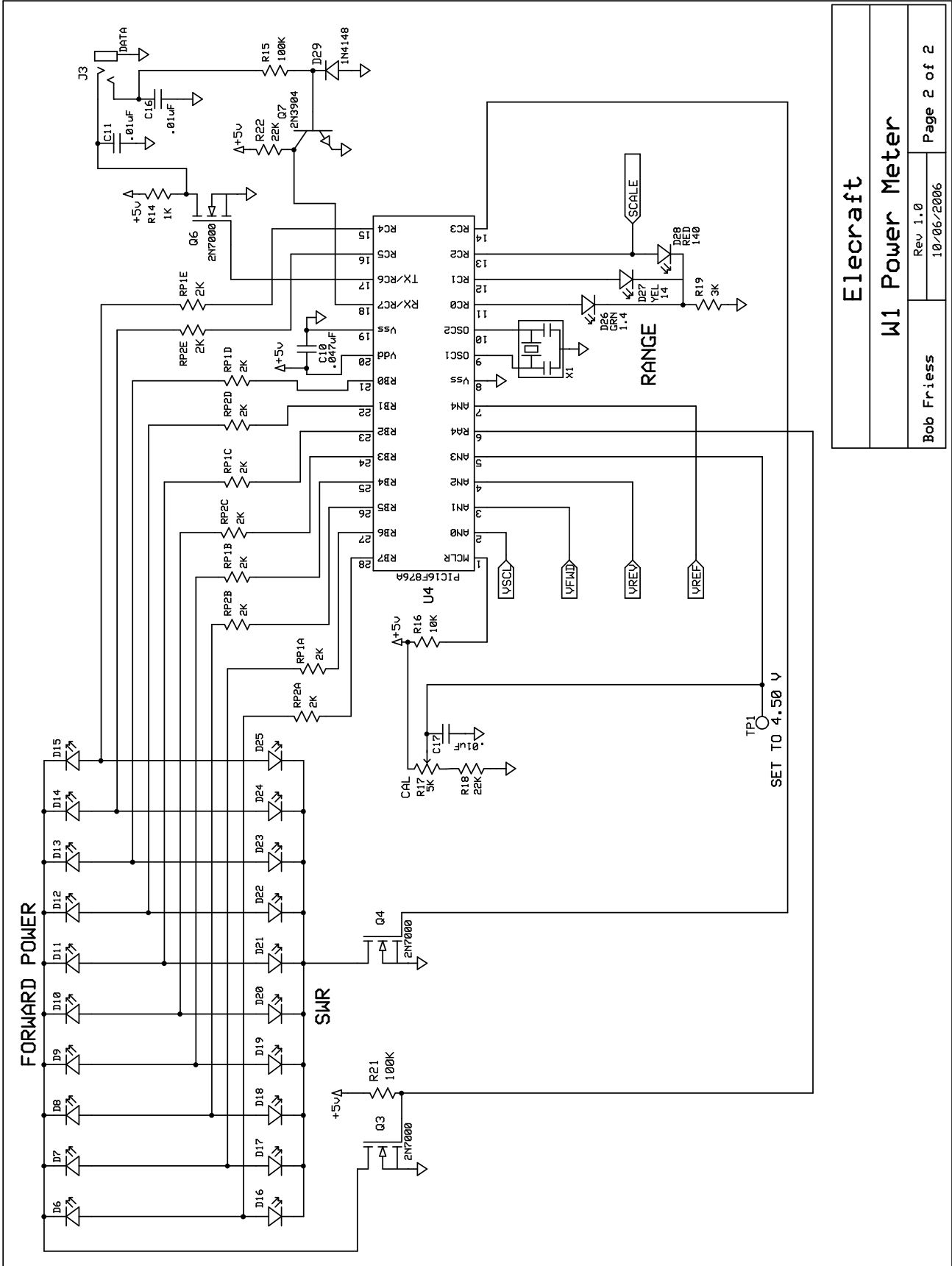

Elecraft	
W1 Power Meter	
Bob Friess	Rev 1.0 10/06/2006
Page 2 of 2	

Serial Interface Commands

The W1 responds to commands for data supplied by the external system. Nothing is sent until a command is received by the W1. These requests are in the form of a single letter as shown below. The user sends a single character and receives one data string in response. The semicolon (;) is an end-of-string identifier, and will be at the end of every return string. All strings are fixed length; a space may be added to some strings to ensure this.

Command		
B	Purpose	Request forward-power bargraph level and present range.
	String Length	5 chars.
	Response	B<L M H>nn;
	Notes	<L M H> is the Range (Low Medium High) nn is 00 (no LEDs lit) to 10 (all LEDs lit).
C	Purpose	Request reverse-power bargraph level and present range.
	String Length	5 chars.
	Response	C<L M H>nn;
	Notes	<L M H> is the Range (Low Medium High) nn is 00 (no LEDs lit) to 10 (all LEDs lit).
D	Purpose	Request SWR bargraph level.
	String Length	4 chars.
	Response	Dnn;
	Notes	nn is 00 (no LEDs lit) to 10 (all LEDs lit).
F	Purpose	Request Forward Power in Watts.
	String Length	6 chars.
	Response	F<n.nn nn.n nnn >;
	Notes	Response is floating point. n.nn is power from 0.000 to 9.99 watts nn.n is power from 10.00 to 99.9 watts nnn is power from 100.0 to 149 watts.
L	Purpose	Toggles W1 LEDs on or off.
	String Length	5 chars.
	Response	L<OFF ON >;
	Notes	Power On default is On.
M	Purpose	Toggles between an Average or PEP display of Forward Power LEDs.
	String Length	5 chars.
	Response	M<AVG PEP>;
	Notes	Current setting can be saved in memory.
N	Purpose	Toggles between an Average or PEP value of Power serial data.
	String Length	5 chars.
	Response	M<AVG PEP>;
	Notes	Current setting can be saved in memory.

Command		
P	Purpose	Toggles between regular LED bargraph or Peak-Hold + bargraph.
	String Length	5 chars.
	Response	PK<NO ON>;
	Notes	Peak-hold default is No. Current setting can be saved in memory.
R	Purpose	Request Reverse Power in Watts.
	String Length	6 chars.
	Response	R<n.nn nn.n nnn >;
	Notes	Response is floating point. n.nn is power from 0.000 to 9.99 watts nn.n is power from 10.00 to 99.9 watts nnn is power from 100.0 to 149 watts.
S	Purpose	Request the SWR value.
	String Length	6 chars.
	Response	Snn.n;
	Notes	nn.n is the SWR from 1.0 to 99.9.
U	Purpose	Request the user settings that were last stored in EEPROM
	String Length	6 chars.
	Response	U<A P><A P><S M F><S M F>;
	Notes	First A or P is Average power or PEP for Forward Power LEDs. Second A or P is Average power or PEP for Forward or Reverse Power serial data. First S or M or F is Slow or Medium or Fast LED decay Rate. Second S or M or F is Slow or Medium or Fast Range drop rate.
V	Purpose	Request the firmware version.
	String Length	6 chars.
	Response	Vn.nn;
	Notes	n.nn is the version of 1.00 to 9.99.
W	Purpose	Writes to EEPROM the user settings currently being used in RAM
	String Length	4 chars.
	Response	WOk; ("Write attempt OK").
	Notes	

Command		
X	Purpose	Request the user settings currently being used in RAM
	String Length	6 chars.
	Response	X<A P><A P><S M F><S M F>;
	Notes	First A or P is Average power or PEP for Forward Power LEDs. Second A or P is Average power or PEP for Forward or Reverse Power serial data. First S or M or F is Slow or Medium or Fast LED decay Rate Second S or M or F is Slow or Medium or Fast Range drop rate.
0	Purpose	Set W1 to Autorange.
	String Length	3 chars.
	Response	A0;
	Notes	This is the power on default.
1	Purpose	Set W1 Range to Low.
	String Length	3 chars.
	Response	A1;
	Notes	
2	Purpose	Set W1 Range to Medium.
	String Length	3 chars
	Response	A2;
	Notes	
3	Purpose	Set W1 Range to High.
	String Length	3 chars.
	Response	A3;
	Notes	
4	Purpose	Set LED decay rate to Slow.
	String Length	3 chars
	Response	HS;
	Notes	Current setting can be saved in memory.
5	Purpose	Set LED decay rate to Medium.
	String Length	3 chars.
	Response	HM;
	Notes	Current setting can be saved in memory.
6	Purpose	Set LED decay rate to Fast.
	String Length	3 chars
	Response	HF;
	Notes	Current setting can be saved in memory.
7	Purpose	Set Range drop rate to Slow.
	String Length	3 chars.
	Response	YS;
	Notes	Current setting can be saved in memory.
8	Purpose	Set Range drop rate to Medium.
	String Length	3 chars.
	Response	Current setting can be saved in memory.
	Notes	
9	Purpose	Set Range drop rate to Fast.
	String Length	3 chars.
	Response	Current setting can be saved in memory.
	Notes	