

The Elecraft KX3 and One Amateur's Weekend Project:  
*A Guide to KX3 Mobile Installation and Operation*  
Matt Zilmer, W6NIA  
10 October, 2012 - Rev 1.3

## Introduction

There can be no doubt that the KX3 is a revolutionary Amateur transceiver. Its technical specs, compact size, light weight, and general versatility perfectly match the requirements of a portable, mobile, or fixed station rig. This Guide is written to assist those interested in the KX3's *mobile* installation and operation.

Essential factors in mobile operation are significantly different than when operating portable or at a fixed station. In many ways, operation of *any* HF transceiver in a mobile setting is non-optimal. Simply put, this means that a series of compromises play out for mobile use, including *both* the installation and operation of the transceiver.

One aspect of KX3 mobile installation and operation that is emphasized in this Guide is safety. No mobile installation should detract from it, so safety is treated herein as a serious issue with specific recommendations that will assist the installer and Amateur operator in maintaining passenger and driver safety.

Topics in this Guide include the following:

- Scope and Warnings
- Safety and Legal Considerations
- Location and Mounting
- Powering the KX3 and KXPA100
- Cabling Like a Pro
- Speaker Output
- Antenna Installation
- Operating Tips
- Updates To This Guide and In Closing

## Scope and Warnings

*Scope Note: This Guide's scope covers only installations in vehicles that have negative ground electrical systems. If your vehicle has a positive ground system, consult your dealer's and/or Elecraft's technical staff for advice on power considerations for the KX3 and KXPA100.*

*Warning Note: Some hybrid vehicles don't use 12 volts for their starting batteries. If your hybrid is in this category, don't even think about using its battery to power your KX3 or KXPA100. In many hybrids an inverter-based DC to DC converter is used to power the 12V accessories (radio, fans, illumination, etc.) and any in-vehicle power sockets. Inverter-supplied power is usually very noisy, and shouldn't be used for the KX3. If in doubt, check your 12V accessory power with an oscilloscope. DC power should meet Elecraft's DC power quality specifications. If it doesn't you may want to add conditioning and filtering circuits to clean up the DC supply.*

## Safety and Legal Considerations

These are some important KX3 mobile safety and legal considerations:

- Road visibility
- Access to vehicle controls
- Minimizing driver distraction
- Intact vehicle safety features
- Security of mounted objects
- Electrical power
- Distracted driver laws

Maximizing road visibility seems like an obvious objective, doesn't it? But many Amateurs sacrifice visibility in favor of keeping their radio equipment in view and accessible. Others mount their rigs in locations that take attention away from what's going on in front of and around their vehicle while driving. However you choose to mount your KX3, it should not interrupt your forward visibility or cause you to take your eyes off the road. This Guide has some mounting suggestions in a later section.

Another goal probably also seems obvious: To be able to drive and control your vehicle normally. Direct visibility of all mirrors and any backup camera display is essential. Access to all vehicle controls used for driving should not be impeded or blocked in any way. For example, it's less critical to block airflow from an A/C vent rather than make it difficult or clumsy to signal a turn or apply the brakes. Your choice of the KX3's mounting location and orientation is crucial here.

A major preventable cause of distracted drivers is personal electronics. Smart phones, tablet computers, DVD players, TV receivers, etc. - all are on the road now. Most of us have at least some of these on hand while we drive. Adding the KX3 in this type of situation could complicate it. If you're busy with the KX3 when driving, keep in mind that its controls are relatively complex compared to a car radio or CD player. Standard vehicle electronics aren't very complex to operate, but not so with some Amateur transceivers. As an example, compare the controls of a mobile VHF FM transceiver to those of a KX3. Of the two, the KX3 will demand much more of your attention to operate.

Your Number One Job when driving is Driving. If a passenger is distracting the driver, the driver should pull over. If a non-essential device in the vehicle is doing the same thing, turn it off. A distracted driver has symptoms similar to one with impaired judgment: Lack of use of sensory inputs, and delayed reactions to those that *are* perceived. Don't let Amateur Radio turn you into a statistic, or into another ham with a sad story to tell others. Let the drive-while-texting folks become the statistics.

In aviation, we have a saying: "Aviate, Navigate, Communicate." First is highest priority. Last is lowest. You could retask that saying for your priorities when piloting a ground vehicle. Keep your priorities straight.

Seat belts and airbags are important vehicle safety features; they save lives. Don't mount your KX3 in a location that interferes with seat belts or proper airbag "deployment". The quotes are there for a reason. If you've never had an airbag deploy in front of you, you wouldn't believe how quickly the KX3 may become a projectile if it's in the way. Airbags move fast, and with explosive force. Anything blocking an airbag's path should be moved out of the way. If there's any doubt about your vehicle's

airbag deployment paths, consult your dealer's technical staff. Airbag locations are marked with a prominent embossed label.

I mentioned "a projectile", above. In a vehicle moving at 65 MPH [105 KPH], a two pound KX3 on a ballistic trajectory can be deadly. Simply put, your KX3 should be securely mounted to a stationary surface in the vehicle interior. Seems like common sense, right? Common sense isn't all that common, unfortunately. There's more about mounting techniques in a subsequent section of this Guide.

One final safety factor: Electrical Power. Don't compromise on the quality, security, location, and especially protection of your DC supply cabling to the KX3. If you have an electrical fire while in motion because of a poor or temporary installation, it's too late to complain, "But it's only temporary!" Man, oh man - talk about distractions while driving!

Distracted Driving Laws: Amateur Radio has come under some of the same fire that is hitting mobile cell phone users. It is true that many of the same hazards exist for both practices, but hams as a population are more used to mobile operations. See <http://www.arrl.org/arrlletter>, then find the 15 December, 2011 edition, second article down. Such laws are a mixed bag. The states of California, Washington, and Hawaii specifically exempt the Amateur population from the provisions of their distracted driver laws, however many of the laws as-written are ambiguous, and refer to "communications with electronic devices". Be aware of the law in your state! Most of these require the use of "hands-free" devices.

Wireless hands-free accessories for mobile two-way are available, but the market is slim. This may be due to low consumer demand. The few Bluetooth hands-free add-ons for two-way are marketed for law enforcement, and are pricey.

Vehicle safety is a big topic with a wide range of considerations. Make yourself aware of the factors in your own mobile installation that could become problems while you're at the wheel. Install your KX3 accordingly. If you're planning a new car/SUV/truck/RV purchase and also would like a KX3 mobile installation in it, survey the interior, electrical system, cable runs and raceways, and vehicle construction before signing on the dotted line. You may want to discuss mounting and cabling arrangements with the dealer's technical staff beforehand.

### Location and Mounting

Ideally, mobile-mounting your KX3 provides the following benefits:

- Accessible and directly visible controls and display;
- One-handed operation;
- A minimum of cable clutter;
- Least possible amount of divided attention while driving – most important!

The good news is that if the KX3 is near enough in front of you, using the controls one-handed shouldn't pose a big challenge, even while driving. Hints are:

- Make sure the KX3 is mounted to one side of the steering wheel. This avoids a cross-handing problem. It is best if the KX3 front panel controls are within an easy reach, or maybe right at your fingertips;
- It's a great idea if you get 100% used to the KX3's controls before ever using the rig while you're driving. It's a case of, "DO try this at home."

With the KX3, we're fortunate to have the I/O connectors on the left panel. For left hand-drive vehicles at least, most of the cabling can be routed over the edge of the dashboard, or behind the instrument panel. The BNC and SMA connectors can be right-angled to the rear of the KX3, keeping the antenna cables out of the way. Don't leave cables scattered on your dashboard because they can be a distraction. Having cables drop off and get wound around your hands or feet makes this much worse. There is more on cabling below.

Several types of vehicle mount that work with the KX3 are readily available. You can always roll your own if needed, but the easiest and usually best course is to use a manufactured mount from one of the following categories:

- **Hard mounting.** This is the case where you'd have to develop your own mount or adapt one that exists. A good source for hard mounts is National Products, with RAM Mount as their brand name: (<http://www.rammount.com/Products/VehicleMounts/tabid/4077/Default.aspx#/>). The downside to a hard mount is that you'll need to drill holes for the mount base. The upside: Hard mounting is the most physically secure type, with a lot of safety margin.
- **Vacuum mount.** An example is a family of products manufactured by Seasucker of Florida (<http://www.seasucker.com/shop/seasuckerram-x-mount-phonegps-holder/>). They're for use in marine environments to secure heavy loads to bulkheads and acrylic surfaces. An example is shown in Figure 1 (next page). Seasuckers are available in 4-1/2- and 6-inch vacuum diaphragm diameters. The 4-1/2-inch unit is adequate when used with the KX3 on auto glass, and is rated at 120 pounds for either axial or radial load. Vacuum mounts do not generally work well on curved surfaces, but a side window or windshield should be okay. This type of mount requires an occasional push of the plunger to maintain its seal on auto glass. "Occasional" means about once a week. There is an indicator showing the vacuum level and if it's getting too low. In the author's opinion, the Seasucker is probably the best no-holes mobile mount base available.
- **Suction mount.** There are a lot of these available, for use with device types from iPods to navigation units. You would probably want a suction mount with a 3-inch or larger suction cup to secure the KX3 against windshield or side-window glass, or on the dashboard. Most come with an adhesive disc that allows a solid mount point on any surface. Arkon is one manufacturer: <http://www.arkon.com/>. There are many others. Any suction mount you use should be rated at five times the KX3's featherweight of 2 pounds. Suction mounts don't perform as well as vacuum mounts, and may lose their grip – dropping the KX3 in your lap when it's least convenient. Suction mounts should be resealed several times a month to maintain retention. They only last about a year, so keep that in mind.
- **Air vent mount.** Most of these are designed for use with very lightweight devices like smart phones and media players. They're available at electronics retailers such as Best Buy. One manufacturer is Bracketton. Vent mounts may sag and most will need periodic adjustment. This alternative is not recommended, but may be the only choice for some mobile users with limited space. Don't count on air vent mounts lasting very long: They have too many moving parts, most of them are too fragile for a lot of mount / dismount cycles, and they're not rated for the KX3's weight.

The Seasucker 6018 with a mounted KX3 is shown in Figure 1, below. Using the 4-1/2" vacuum mount, the KX3 is secured to the driver side window of a 2012 Honda Civic. Also note the cable dress and clearance to the curtain airbag's deployment path (driver's side post in background).



Figure 1. Seasucker 6018 vacuum mount with a KX3 in a Honda Civic. The piece of paper to the KX3's rear was used to block sunlight for purposes of shooting the photograph.

## Powering the KX3 and KXPA100

Vehicle accessory power systems are notorious for conductive emissions, and they may come in many forms – both transient and steady state:

- Load dump surges
- Engine starting transients
- Inverter noise (hybrids, especially)
- Poor line isolation (fan motors, relays, and solenoids)
- Transients due to accessories being switched on and off (a/c compressors and electric fuel pumps are two examples)

The very best source of power in a typical vehicle is a secondary battery. Note that I didn't write this as "the engine start battery". Your engine start battery will work too if it's 12V, or you could tap into an unused branch circuit at the fuse block. Least desirable as a power source is the vehicle's accessory electrical system.

A secondary battery that's well-isolated from the vehicle's engine-start system will work best for the KX3. There are a number of isolators made for 12VDC systems, and these are used to connect the secondary battery to the vehicle's DC system only for charging, as needed. Some isolators also supply transient suppression and filtering, and over-current protection. In general, this will eliminate or suppress conducted emissions from the primary accessory power system. See <http://www.powerstream.com/battery-isolator-solid-state.htm> for an example of an isolator.

In practice, not everyone can fit in a second storage battery to use for the KX3. Small cars in particular have little space for extras like this. You might be able to fit a small battery under a seat or in the trunk, but take care to protect its terminals from being shorted, and it should be securely mounted. Most of us would probably choose to use the vehicle's engine start battery as the primary KX3 power source. This approach is generally the best compromise for power quality, cost, and convenience. The KX3 power distribution and conversion example in this Guide uses the engine start battery as the source.

The KX3 was designed to operate from clean DC power – batteries – and is *not* immune to automotive DC power supply impurities (I call this "gudge"). If any DC line noise is present at audio frequencies, it will be readily audible in the KX3's speaker and PHONES output. (The microphone amplifier circuits are not as susceptible to line noise.) One way to mitigate a DC source with audio frequency noise is to use the KX3's RX SHFT function to move amplification away from the audio frequencies, up to 8 KHz. This works amazingly well. But it's even better if you remove the DC line noise entirely, or lessen it substantially.

Power distribution to the KX3 and the KXPA100 may be routed via an automotive relay with instrument panel control via a switch. Shown in the wiring diagram, Figure 2, this separate switching allows the operator to avoid engine start transients at the KX3, which could be damaged by transient spikes. The switch and relay can be purchased from your local auto parts dealer. See Figure 4 for a photo of the interior switch in a Honda Civic. Figure 5 shows the relay enclosure, mounted in the Civic's trunk.

*Caution: DO NOT use panel switches like the one shown to directly switch loads such as the KX3 or KXPA100. Switches of this type are designed for the amount of current a relay coil needs to energize, 0.5A or less. Let the relay do the heavy lifting; it only costs a couple of dollars.*

Figure 2, below, shows a wiring diagram for a KX3 and a KXPA100 installation – both powered from the vehicle’s engine start battery. This design uses a relay to isolate the KX3 / KXPA100 branch circuit.

Figure 3 is a schematic diagram of the relay and power interconnect circuits. The diode is used to protect the contacts on the panel switch shown in Figure 4 from back EMF when the relay coil is de-energized.

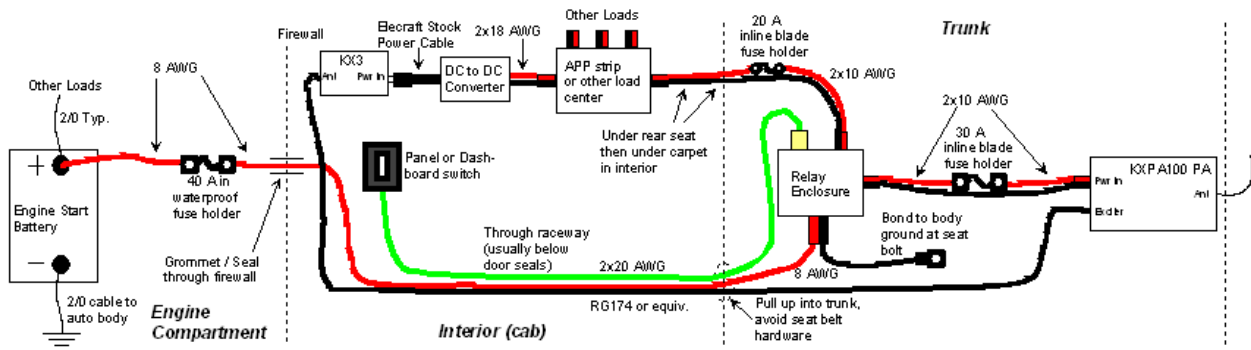

Figure 2. Wiring Diagram: Example of KX3 and KXPA100 power and antenna cabling.

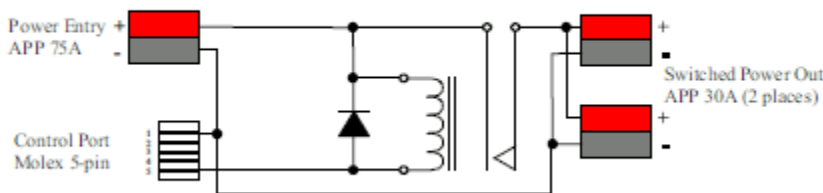

Figure 3. Relay and interconnection schematic.

In Figure 2, take a close look at the KX3’s DC power input. The DC to DC converter shown eliminates whatever power impurities remain at this end of the interior DC branch circuit. Being a boost-buck regulator, the converter can accept a wide range of input voltages and produces a steady 13.8VDC (adjustable). The converter used in this example installation is made by QSKJ (model QS-1212CCBA-80W). In addition to cleaning up the DC, the converter reduces voltage sag from the smaller gauge interior wiring. In order to prevent the converter from introducing its own emissions, a Laird LFB174095 ferrite core was used with 3 turns of the KX3’s stock cable. This killed all converter emissions. See <http://ca.picclick.com/DC-DC-Converter-QS-1212CCBA-80W-Power-Supply-251036051706.html>.

## Cabling Like A Pro

If you take time to plan your cabling carefully, power and antenna cables will be visible only at the KX3, under the hood [bonnet] when it's up, or in the trunk [boot]. The idea is to keep your car or truck interior looking uncluttered. If you don't care about cable placement you may ignore this section. Some people are neat freaks, others aren't.

There are numerous useful tricks in performing a pro installation. We can learn a lot from mobile audio installers on this, taking advantage of the fact that there is a general trend to install monster audio gear. Many vehicle audio systems involve placing a high-power amplifier in the trunk, with a head-end unit in the cab, and heavy power and speaker cabling in between. That same placement concept can be used for the KX3 and KXPA100.

*Note: Although the KXPA100 is not yet available from Elecraft, as of July, 2012, the design team confirmed it will use the 30A Anderson Power Pole connector, so design accordingly.*

When exiting your power cable from the engine compartment, first locate a suitable punch-out grommet or seal. Most of these are circular, and vehicle manufacturers leave a few spares for aftermarket equipment installations. Locations and sizes of these entry grommets vary by vehicle. Your dealer's technical staff may be able to assist you in finding an appropriate power entry point. Be sure and replace the grommet when done (yes, with a hole cut for the cable).

Using existing interior cable raceways is recommended. To access these, you'll usually need to remove interior panels. Most raceways are located under the doors, and there is normally enough space left to lay in your power, antenna, and any control cabling. Use caution when removing panels and don't lose any of the retainer hardware. You'll need it when replacing the panels.

When it comes to your vehicle's trunk, consider laying in and securing all cables under the liner. Not all trunks have these, but most do. Since the trunk's main purpose is for stowage, you probably want to protect the cables from getting beat up by whatever you toss in there. Use cable ties liberally, especially when suspending wiring and cables from an understructure or near vertical mounting locations.

Here are a few hints that apply whether you install your KX3 cabling or have someone do it for you:

- Use the correct wire gauge (see Table 1 below) and terminations;
- Make room for fuse holders at the source end of each power cable run;
  - o Blade-style fuses and fuse holders are readily available at auto parts stores and mobile audio dealers;
  - o Fuses located under the hood should be housed in waterproof fuse holders;
  - o All fuses, of any type, should be DC-rated.
- Try to route engine compartment cabling so it can be cable-tied to the wiring harness [loom];
- Where possible, use existing cable raceways;
- Avoid radical bends in cables and "crimp points" where the cable jacket can get mashed, mangled, squeezed, ruptured or exposed to similar indignities;
- Allow adequate service loops at cable ends;



*Auto Electronics 101: Every circuit that branches from a source should be protected for over-current.*

At a minimum, you should protect your radio branch circuit with a fuse at the battery. Figures 5, 6, and 7 illustrate over-current protection at multiple locations:

- Battery: 40A inline cartridge fuse in waterproof holder (Motorola p/n 9C84277B02);
- Two branches from relay: 30A blade fuses in water resistant holders;
- West Mountain APP Power Strip: five branches, each protected by a blade fuse.

Wire gauge is an important factor because it determines the loaded terminal voltage at the KX3 and/or KXPA100. Some typical power cable runs are shown in Table 1, below. The goal is to maintain 13.0VDC or higher at the load when the engine is running. Voltages may vary lower than shown when the engine is idle or off, so bigger is better.

AWG	$\Omega$ / kft (km)	L in ft (m)	Current	Load Volts	Use Case or Example
14	2.58 (8.51)	6 (2)	2A	13.7	KX3-only in small car
12	1.62 (5.34)	10 (3.3)	2A	13.7	KX3-only in pickup truck
10	1.02 (3.37)	15 (4.9)	25A	13.0	KX3 in cab with KXPA100 under seat
8	0.64 (2.11)	25 (8.3)	25A	13.0	KX3 in cab with KXPA100 in trunk

Table 1. Practical wire gauges and lengths for the KX3 and KXPA100 in a mobile setting. DC resistances shown are at 77 deg F, 25 deg C. Source voltage used is 13.8VDC.

For normally constructed, negative ground vehicles (Unibody), only the positive lead is needed for power. The vehicle body can and should be used, where possible, as the return or ground. Running a separate return is generally not necessary and saves money as well. Seat-mount bolts make good ground bonds and they're accessible. You can use them as grounds near the loads.

When you perform your own voltage drop calculations, be sure and include the contact resistance of all connectors in the series circuit to the load. The table above assumes APP connectors as shown in the photos.



Figure 4. 40A branch circuit power switch on the Civic's instrument panel. There were two "dummies" in this panel, so I removed the rightmost one and filled its slot with a Honda standard switch replacement. The KX3 and mount aren't seen, but they are located directly above this panel. The microphone cable is shown hanging at the left.



Figure 5. Trunk-mounted relay enclosure and cabling. The 8 AWG battery power feed enters the enclosure via the APP pair on the left. Behind it is the control input wiring from the panel switch shown in Figure 4. The 10 AWG power cable exiting to the right is protected by a 30A inline blade fuse. It's routed under the rear seat and carpet to the in-cab West Mountain 5x APP strip shown in Figure 6 on the next page. The enclosure and all cable ties are secured to the rear deck's metal understructure. Note the hard-point ground at the right – used to provide a solid ground for the antenna.

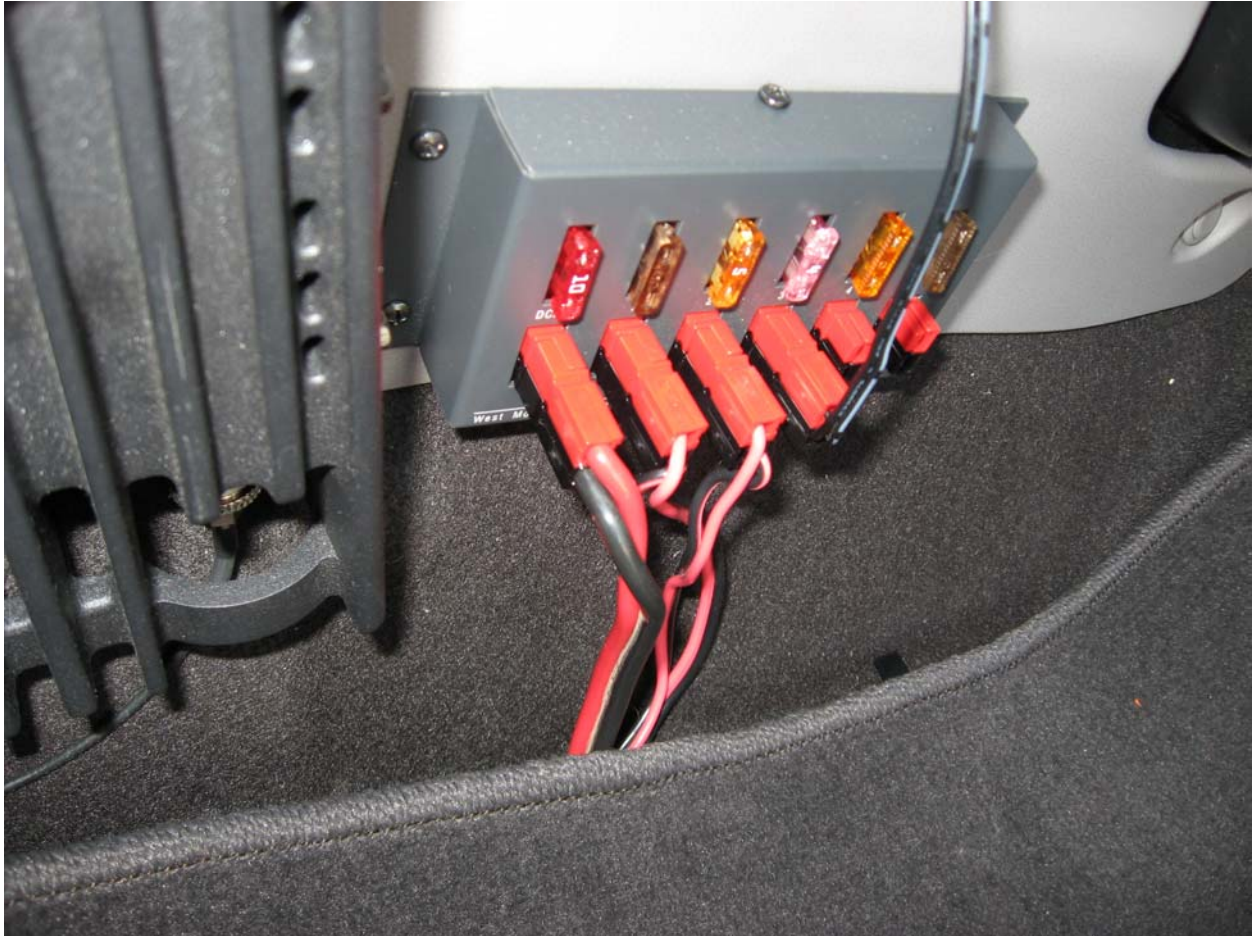

Figure 6. West Mountain APP strip feeding the KX3 and other radios. The 10 AWG power feed from the trunk-mounted relay enclosure is visible on the left. The 10 AWG is fished from the front edge of the rear seat under the carpet to its exit point about six inches to the left of the APP strip (under the passenger seat). An upholstery "hook knife" was used to slit the carpet and liner to allow the cable an exit. The ground used at this location is one of the passenger seat bolts. The input is fused at 10A, which will be changed to 30A when the two empty circuits are populated (future planning).



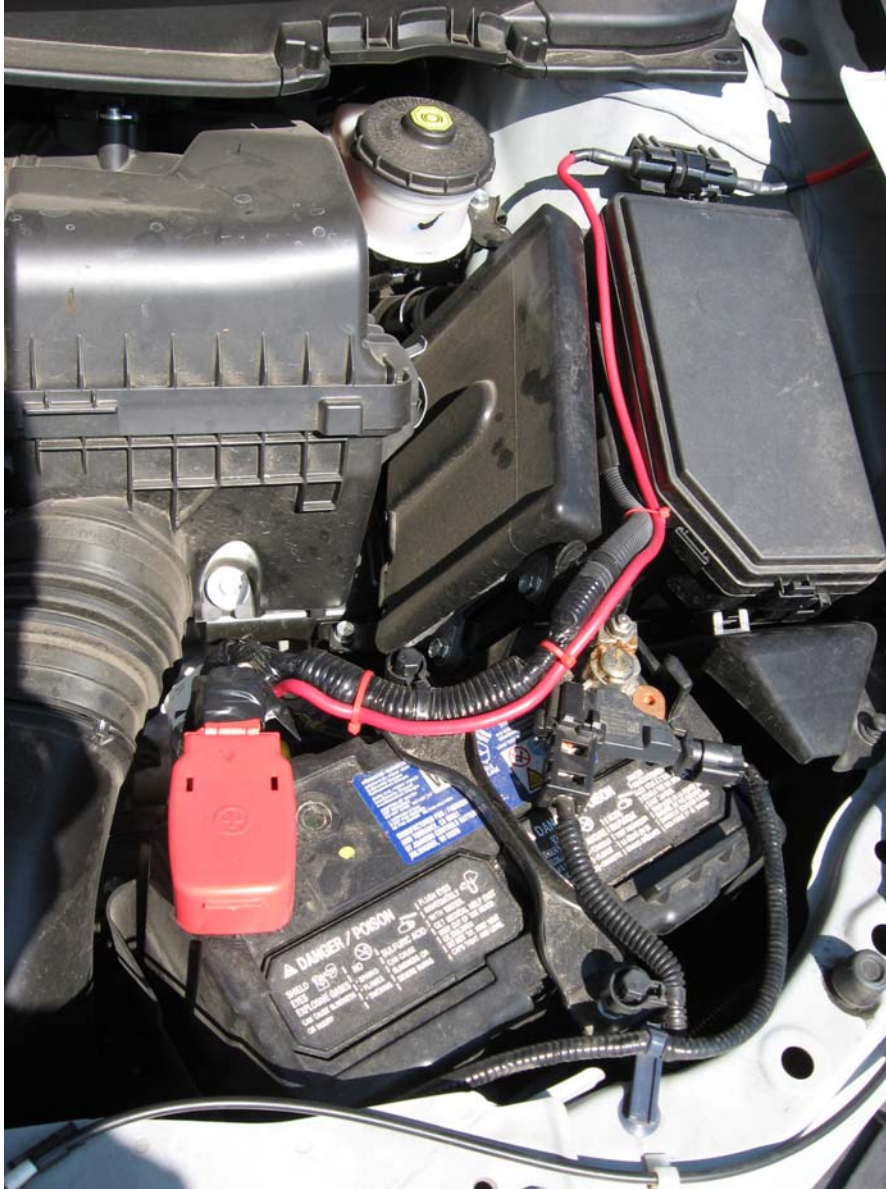

Figure 7. Engine compartment, 8 AWG battery cabling, and 40A inline fuse in fuse holder (upper right). The Motorola fuse holder is waterproof. Unseen in this photo, there is a short length of 5/16" fuel hose slipped over the cable jacket to the right of the fuse holder, to protect it as it traverses several sharp metal edges (weld points).

## Speaker Output

The KX3's PHONES socket is a stereo 3.5mm type. If your vehicle has a 3.5mm AUX input, you can buy a patch cable to bring the KX3's PHONES audio to your car's audio system. Elecraft sells a nice right-angle 3.5mm cable for this purpose, and they also have a kit of four cables available for a complete PC-sound and control connection (SKUs E980230 and KX3-PCKT, respectively). The Elecraft cables work very well for KX3-mobile sound connections because of the right-angle connector at the KX3. They're high quality cables, not generally what you would find at Best Buy or Target.

It's best to isolate the KX3 output with a 1:1 600ohm or lower transformer. This will help prevent audio artifacts from being heard at high volume, and avoids ground loops (Pin 1 problems).

If your vehicle doesn't have an AUX input, there are kits available for retrofitting older car audio. Most of these use the CD Changer input. If you want separate powered speakers, there are dozens of choices but make sure you can fit them in the interior, and that they're securely mounted.

## Antenna Installation

Figures 8 and 9, on the next page, show one possibility for a mobile HF antenna. I'm using this on my Honda Civic regularly. The antenna shown in Figure 8 is a Hustler single-bander for 40m, using the short 22" mast and a base spring at the resonator mount point. This is an inexpensive type of mobile antenna, and not incredibly efficient, but it does work. I've had 60 or 70 SSB contacts while mobile, and about 200 CW contacts while stationary using the Hustler as shown.

The tripod mount configuration shown in Figure 9 is extremely robust. The main mount and feed point is at the rear lip of the trunk lid. Two Comet RS480 5/8" trunk mounts are used at the forward lip for longitudinal and lateral stability. I've been able to use the largest Hustler resonators, and even a home-brew 100W resonator that I hand-built for a 5 MHz MARS frequency. The two forward legs of the tripod are made of 3/8" fiberglass rod acquired from Granger. The brackets are made from scrap aluminum found around my shop. Level adjustment is via the two 3/8-24 coupling nuts near the front attach points. Metal and fiberglass are held together at both ends of each forward leg, using two-part epoxy. Heat shrink tubing is used to hide the ugly part of each metal-fiberglass junction.

### Hints:

- When stationary, lay out a couple of quarter wave radials and attach them to the vehicle chassis. Fan them out to the sides from the rear of the vehicle. This really helps with efficiency and gets a bigger signal on the air. QRP mobile isn't really a good combination with small antennas and no substantial counterpoise. The vehicle chassis doesn't really help much as a counterpoise, unless the vehicle is RV-sized. Putting out radials will *always* improve your radiated signal.
- Use higher power levels. The KXPA100 will help with this.
- The part of the antenna mount that is mechanically attached to the vehicle should be electrically *grounded* to a hard point on the vehicle's body. Don't depend on a trunk lid, and its attachment via hinges to the rear deck, to be a reliable ground. Use some coax braid from the mount base and route it along the trunk frame using cable ties as needed. There's usually a good attach point right on the body metal near the trunk hinge attach points. If you examine Figure 5 closely, there is a good hard attach point shown at the far right.

There are probably dozens of more electrically efficient mobile antennas to choose from. My favorite is the HiQ, but it's not a very comfortable fit for a small car like a Civic.



Figure 8. Trunk lip-mounted Hustler short mast with a 40m resonator attached.



Figure 9. Detail shot of the tripod mount and the Hustler short mast.



## Operating Tips

Though the KX3 is an excellent mobile platform, there are a few hints that may assist operators. Some of these are described below. As emphasized elsewhere in this Guide, safety is a primary consideration.

While you're stationary, put in the settings you'll use while driving. Adjust the AF and RF GAIN levels, and set the BAND and VFO A / B up near the frequency you intend to use. Turn the PREAMP on or off as needed, and set the Noise Blanker on to kill ignition and other radiated noise. Make sure all the KX3 cabling is in place, and that the rig is secured in its mount. Set the MODE as desired.

- While driving, use the UP / DN buttons on the MH3 mic for frequency changes, rather than twisting the VFO A knob. Avoid "frobbering" the VFO except as needed for fine tuning. The mental feedback loop between turning the VFO knob and watching the display is potentially a 100% distraction from driving. However, you will need to make fine adjustments once in a while. Instead of watching the display, listen to the signal instead, as you adjust the VFO.
- Unless you're a seasoned CW op, stick to voice modes while driving. CW using the KXPD3 (attached to the KX3) is not recommended while mobile. If CW is *your mode*, you'll likely want to remote-mount a key or paddle in a comfortable position, but probably away from the KX3.
- Use the SCAN function instead of "roving" via VFO A. This requires that a memory with A and B frequencies be recalled before scanning. You may want to set up specific memories for mobile operation just for this purpose. You can use the MH3 microphone's UP and DN switches to halt a scan in progress. The KX3 will scan manually if you use the mic switches - either tap or hold.
- If you're driving in the city, the KX3 could experience various signal degradations and obstructions. Sources are buildings and other large objects like bridges, fence lines, high-voltage transmission lines, etc. These are unavoidable, and are part of the mobile operator's "landscape".
- If you're operating mobile in the countryside, you may notice several types of RFI. Sources include: power lines and utility equipment, street lighting, diesel fuel injectors, ignition noise, etc. The KX3's Noise Blanker is *very* effective in eliminating these.
- Set up PF1 and PF2 for frequently-used MENU functions. For example, PF1 can be set up to toggle the backlight on/off, and PF2 set up for DUAL RX on/off. Don't put yourself in a position, while driving, of needing to access MENU functions at all.

## Standard Disclaimer, Updates To This Guide, and In Closing

As stated in the subtitle, this guide is “one ham’s weekend project”. It’s not meant to be all-definitive, because the ham population chooses from a diverse set of vehicles and there is a lot of variation in mobile conditions for operators – for a variety of reasons. Again, safety should not be compromised in any case, and frankly, each operator must make his or her own choices for mounting, cabling, over-current protection, etc. I suppose that this is a soft way of saying that the author is not responsible for the decisions you make when it comes to any Amateur mobile installation, even if you follow this guide’s installation to the last detail.

Periodic changes and corrections to this document may be necessary and will be published when needed. Readers are encouraged to contact the author with any type of feedback. Email: [blatzabel@gmail.com](mailto:blatzabel@gmail.com). I hope this guide to was useful to you. That is my goal.

## Revision History and Credits

<u>Revision</u>	<u>Date</u>	<u>Change Set</u>
0.9	21 JUL 12	First rough draft, review by Elecraft. Content only.
0.95	23 JUL 12	Added some photos, electrical schematic.
1.0	28 JUL 12	First review copy, format cleanups. Worked with Metro Honda service dept. for airbag deployment and Seasucker safety checks.
1.1	30 JUL 12	Added battery side and pull-through pics (cabling).
1.2	2 AUG 12	Restructured with better formatting for photos, Added explanation of the schematic, coupled with the under-hood and trunk photos.
1.3	10 OCT 12	Re-wrote antenna mount section, showing the tripod after Initial testing. Thanks to Roger Wright of Advanced Radio Workshop for the assistance! Thanks to Don Wilhelm for proofreading.