

# ELECRAFT®

## KAT500 AUTOMATIC ANTENNA TUNER



## OWNER'S MANUAL

Revision B2, November 13, 2012

Copyright © 2012, Elecraft, Inc.

All Rights Reserved

# Contents

Introduction.....	1
Quick Start.....	1
Customer Service and Support .....	1
Technical Assistance.....	1
Repair / Alignment Service.....	1
Specifications.....	2
Setup .....	3
Cabling.....	3
Elecraft K3 Transceiver and KPA500 Amplifier using DB15 Interface Cables.....	3
Elecraft K3 Transceiver and KPA500 Amplifier with Separate Key Line .....	5
General Cabling Requirements .....	7
Interface Cable Wiring.....	8
DB15 Interface Cable.....	8
Icom AH-4 Interface .....	8
Operation .....	9
Tuning.....	9
Fine Tuning .....	10
Cancel Tuning.....	10
Alternate Tuning Commands .....	10
Bandswitching.....	11
Turning the KAT500 Off .....	11
Fault Conditions .....	11
Utility Program .....	12
KAT500 Configuration .....	12
Antennas.....	12
Thresholds.....	12
Memories.....	12
Saving Configuration .....	12
Parameter Initialization (EEINIT).....	13
Updating Firmware .....	13
Kit Assembly Procedure .....	14
Preventing Electrostatic Discharge Damage .....	14
Tools Required.....	14
Assembly Procedure.....	15
Appendix A Parts List .....	32
KAT500 Circuit Board.....	32
KAT500 Core Assembly – E850561 .....	32
Wrapped Covers E850565 .....	32
Wrapped Panels E850564 .....	33
Serial Number Envelope E850549.....	33
Miscellaneous Bag E850562.....	33



Elecraft manuals with color images may be downloaded from

[www.elecraft.com](http://www.elecraft.com).

# Introduction

The KAT500 Automatic Antenna Tuner is designed to be closely integrated with the Elecraft K3 transceiver and the Elecraft KPA500 amplifier although it may be easily used with other transceivers and amplifiers. Features include:

- Automatic band switching, covering the spectrum from 1.8 through 54 MHz.
- Automatic antenna switching to connect one of three antennas according to the band selected.
- L and C settings for lowest SWR are stored in memory for extremely rapid frequency and band changes.
- Robust self-protection circuits that guard against damage from switching high-power RF or trying to match loads outside of its tuning range.
- Static bleed resistor built in to avoid damage from normal static buildup on antennas.
- Low profile enclosure that matches the footprint of the KPA500 and K3, allowing the KAT500 to be placed on top or under either unit (the KAT500 is designed to support the weight of the KPA500).

 **If you purchased your KAT500 as a kit, turn to page 14 for assembly instructions.**

## Quick Start

To quickly set up and get started with your KAT500 Automatic Antenna Tuner, turn to page 3 to hook up the unit and page 8 for operating instructions.

## Customer Service and Support

### *Technical Assistance*

You can send e-mail to [k3support@elecraft.com](mailto:k3support@elecraft.com) and we will respond quickly - typically the same day Monday through Friday. Telephone assistance is available from 9 A.M. to 5 P.M. Pacific time (weekdays only) at 831-763-4211. Please use e-mail rather than calling when possible since this gives us a written record of the details of your problem and allows us to handle a larger number of requests each day.

### *Repair / Alignment Service (We want to make sure everyone succeeds!)*

If necessary, you may return your Elecraft product to us for repair or alignment. (Note: We offer unlimited email and phone support to get your kit running, so please try that route first as we can usually help you find the problem quickly.)

**IMPORTANT: You must contact Elecraft before mailing your product** to obtain authorization for the return, what address to ship it to and current information on repair fees and turnaround times. (Frequently we can determine the cause of your problem and save you the trouble of shipping it back to us.) Our repair location is different from our factory location in Aptos. We will give you the address to ship your kit to at the time of repair authorization. *Packages shipped to Aptos without authorization will incur an additional shipping charge for reshipment from Aptos to our repair depot.*

## Elecraft's 1-Year Limited Warranty

This warranty is effective as of the date of first consumer purchase (or if shipped from factory, date product is shipped to customer). It covers both our kits and fully assembled products. For kits, before requesting warranty service, you should fully complete the assembly, carefully following all instructions in the manual.

**Who is covered:** This warranty covers the original owner of the Elecraft product as disclosed to Elecraft at the time of order. Elecraft products transferred by the purchaser to a third party, either by sale, gift or other method, who is not disclosed to Elecraft at the time of original order, are not covered by this warranty. If the Elecraft product is being bought indirectly for a third party, the third party's name and address must be provided to Elecraft at time of order to insure warranty coverage.

**What is covered:** During the first year after date of purchase, Elecraft will replace defective or missing parts free of charge (post-paid). We will also correct any malfunction to kits or assembled units caused by defective parts and materials. Purchaser pays inbound shipping to Elecraft for warranty repair, Elecraft will pay shipping to return the repaired equipment to you by UPS ground service or equivalent to the continental USA and Canada. Alaska, Hawaii and outside U.S. and Canada actual return shipping cost paid by owner.

**What is not covered:** This warranty does not cover correction of kit assembly errors. It also does not cover misalignment; repair of damage caused by misuse, negligence, or builder modifications; or any performance malfunctions involving non-Elecraft accessory equipment. The use of acid-core solder, water-soluble flux solder, or any corrosive or conductive flux or solvent will void this warranty in its entirety. Also not covered is reimbursement for loss of use, inconvenience, customer assembly or alignment time, or cost of unauthorized service.

**Limitation of incidental or consequential damages:** This warranty does not extend to non-Elecraft equipment or components used in conjunction with our products. Any such repair or replacement is the responsibility of the customer. Elecraft will not be liable for any special, indirect, incidental or consequential damages, including but not limited to any loss of business or profits.

## Specifications

<b>Frequency Range</b>	1.8 to 54 MHz, continuous.
<b>Supply Voltage and Current</b>	11 to 15 VDC, 1.5A max (200 mA typical).
<b>Weight</b>	4.6 lbs (2.1 kg).
<b>Size</b>	Enclosure only, 1.5 x 10.8 x 10.0 in., HWD (3.8 x 27.4 x 25.4 cm). With projections, 1.75 x 10.8 x 11.8 in. (4.4 x 28.4 x 30.0 cm). The projections are the bottom feet and the cable connectors on the rear.
<b>Typical Matching Range and Power Limits</b>	3 — 30 MHz    600W into 5 $\Omega$ to 500 $\Omega$ (10:1 SWR). 1000W into 16 $\Omega$ to 150 $\Omega$ (3:1 SWR).
	1.8 — 2 MHz    600W into 10 $\Omega$ to 500 $\Omega$ (5:1 Low Impedance, 10:1 High Impedance SWR).
	30 — 60 MHz    500W into 5:1 SWR (10 $\Omega$ to 250 $\Omega$ ).
	<i>Matching specified to a 1.0:1 to 1.6:1 output SWR. Power rating is ICAS (Intermittent Commercial and Amateur Service).</i>
<b>Autotune Power Range</b>	10W —100W. <i>For better matching accuracy, tune with &gt;20W.</i>

## Setup

**⚠ NOTE: Although the KAT500 works equally well with either a transceiver or a stand-alone transmitter, transceiver is used throughout this manual for simplicity.**

The KAT500 can be used with any 1.8 through 54 MHz transceiver in the 20 to 1000 watt output range, although the KAT500 integrates most closely with the Elecraft K3 transceiver and the KPA500 amplifier.

The KAT500 may be placed under or above either the Elecraft K3 transceiver or the KPA500 solid state amplifier. The KAT500 can easily handle the weight of the KPA500 amplifier. The KPA500's footprint matches both units and the feet provide adequate spacing for proper cooling of the K3 or KPA500.

## Cabling

Diagrams are provided below for stations using the Elecraft K3 and KPA500. Refer to *General Cabling Requirements* on page 7 for using the KAT500 with other equipment.

- Elecraft K3 Transceiver and KPA500 Amplifier using DB15 interface cables.
- Elecraft K3 Transceiver and KPA500 Amplifier with a separate Key line that can be used to control external equipment (e.g. a Stepper-IR antenna controller).

### ***Elecraft K3 Transceiver and KPA500 Amplifier using DB15 Interface Cables.***

Refer to Figure 1 (page 4) and the following notes:

- ① 50-ohm coaxial RF cables with PL-259 connectors. When using a transceiver with multiple antenna outputs such as the K3, be sure the correct antenna connection is selected. The KAT500 allows up to three antenna connections, selected from the front panel (See *Operation*, pg 8).
- ② Two wire power cable with a female 2.1 mm coaxial connector (supplied). Connect to the station 11 to 15 VDC power supply with the white striped lead to the positive terminal. **Do not** take this power from the K3's 12 VDC output connector, even if it has been upgraded for 1 Ampere.
- ③ DB15 interface cables with male and female connectors. Do not use common VGA cables; they are not wired correctly for this use (See *Interface Cable Wiring* on page 8). You can order E850463 from Elecraft or you can make your own. These cables provide the best integration of the KAT500 with the K3 and KPA500 by:
  - Including the essential Key line that inhibits the KPA500 amplifier. The Key line circuit passes through the KAT500 where it is automatically opened whenever a KAT500 tune operation occurs. This inhibits the KPA500 to avoid applying excessive RF power while the KAT500 is tuning. If you need access to the key line to control external equipment, see *Elecraft K3 Transceiver and KPA500 Amplifier with Separate Key Line* on page 5.
  - Providing band data from the K3 to the KAT500 that allows it to switch to the current band at the same time as the K3 instead of waiting until RF is applied and allows the KPA500 amplifier to send the K3 status information (see the *KPA500 Owner's Manual* for complete details).

④ Computer interface cable with a 3.5 mm T-R-S connector at one end and USB connector at the other end supplied with the KAT500 (supplied). Not required for normal operation, but used for controlling the KAT500 from a personal computer, customizing the KAT500's operation or for updating firmware (see *Utility Program* on page 12).

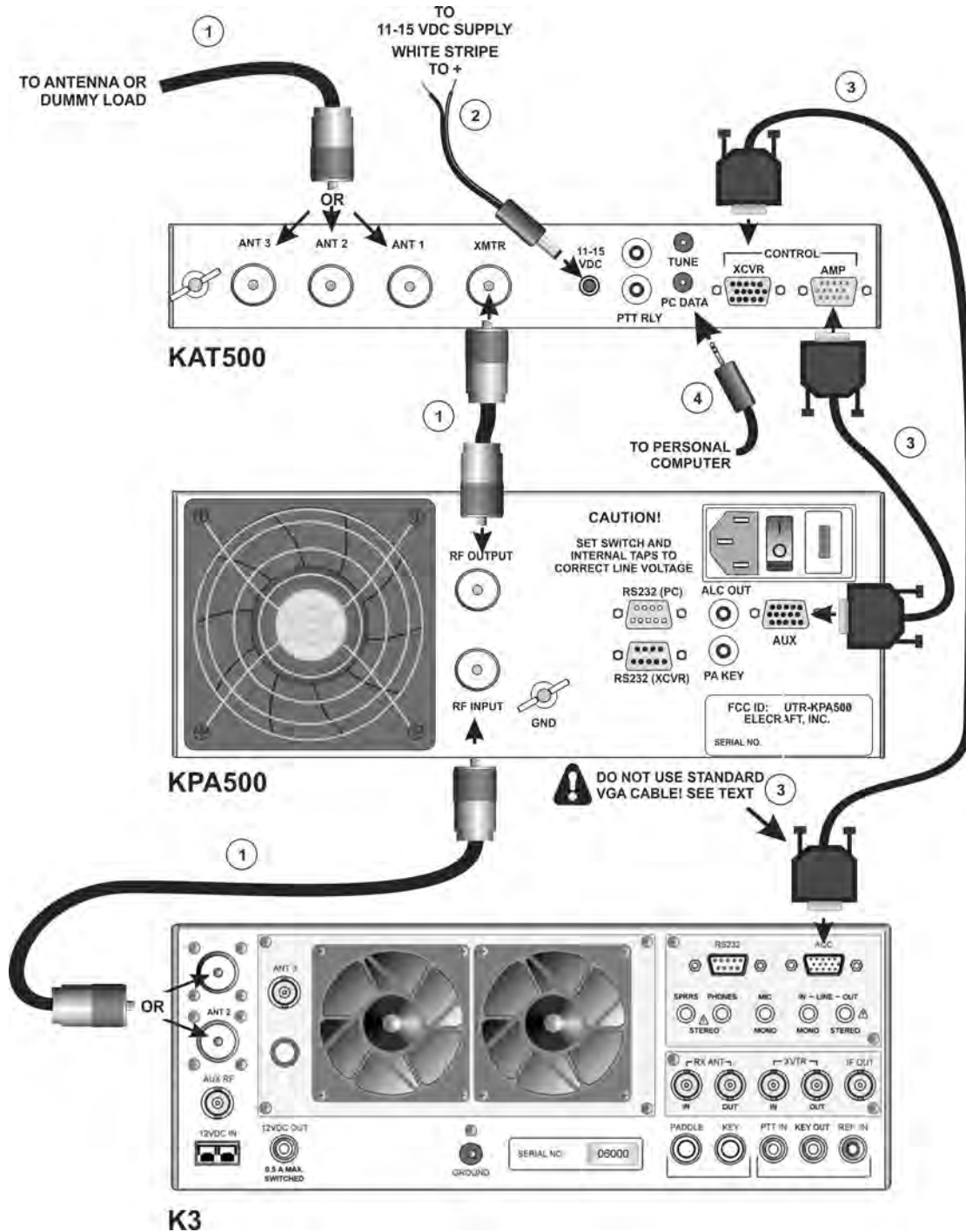

Figure 1. Cabling Diagram: Elecraft K3, KPA500 and KAT500 Using DB15 Interface Cables.

## *Elecraft K3 Transceiver and KPA500 Amplifier with Separate Key Line*

Refer to Figure 2 (page 6) and the following notes:

- ① 50-ohm coaxial RF cables with PL-259 connectors. When using a transceiver with multiple antenna outputs such as the K3, be sure the correct antenna connection is selected. The KAT500 allows up to three antenna connections, selected from the front panel (See *Operation*, pg 8).
- ② Two wire power cable with a female 2.1 mm coaxial connector (supplied). Connect to the station 11 to 15 VDC power supply with the white striped lead to the positive terminal. **Do not** take this power from the K3's 12 VDC output connector, even if it has been upgraded for 1 Ampere.
- ③ Power Amplifier Key cables with RCA connectors (one cable supplied). These cables inhibit the amplifier to avoid applying excessive RF power while the KAT500 is tuning. You may add other equipment that requires the amplifier be inhibited in series with this circuit at any point. The circuit inside the KPA500 is a simple relay closure, so it does not matter which connector goes into each jack.
- ④ DB15 interface cables with male and female connectors. **Do not use common VGA cables; they are not wired correctly for this use.** These cables are optional since a separate PA Key line is used, but they provide band data from the K3 to both the KAT500 and KPA500, allowing them to switch bands instead of waiting the them to sense the frequency and switch bands when RF power is applied.

### **IMPORTANT:**

**The key line in the DB15 interface cable must be opened so that external equipment inserted in the key line can inhibit the amplifier when needed. You can order the KPAK3AUX Elecraft cable set which includes the key line interrupter or you make your own cable and leave pin 10 at the connectors open (see *Interface Cable Wiring* on page 8).**

- ⑤ Computer interface cable with a T-R-S connector at one end and USB connector at the other end supplied with the KAT500. Not required for normal operation, but used for controlling the KAT500 from a personal computer, customizing the KAT500's operation or for updating firmware (see *Utility Program* on page 12).

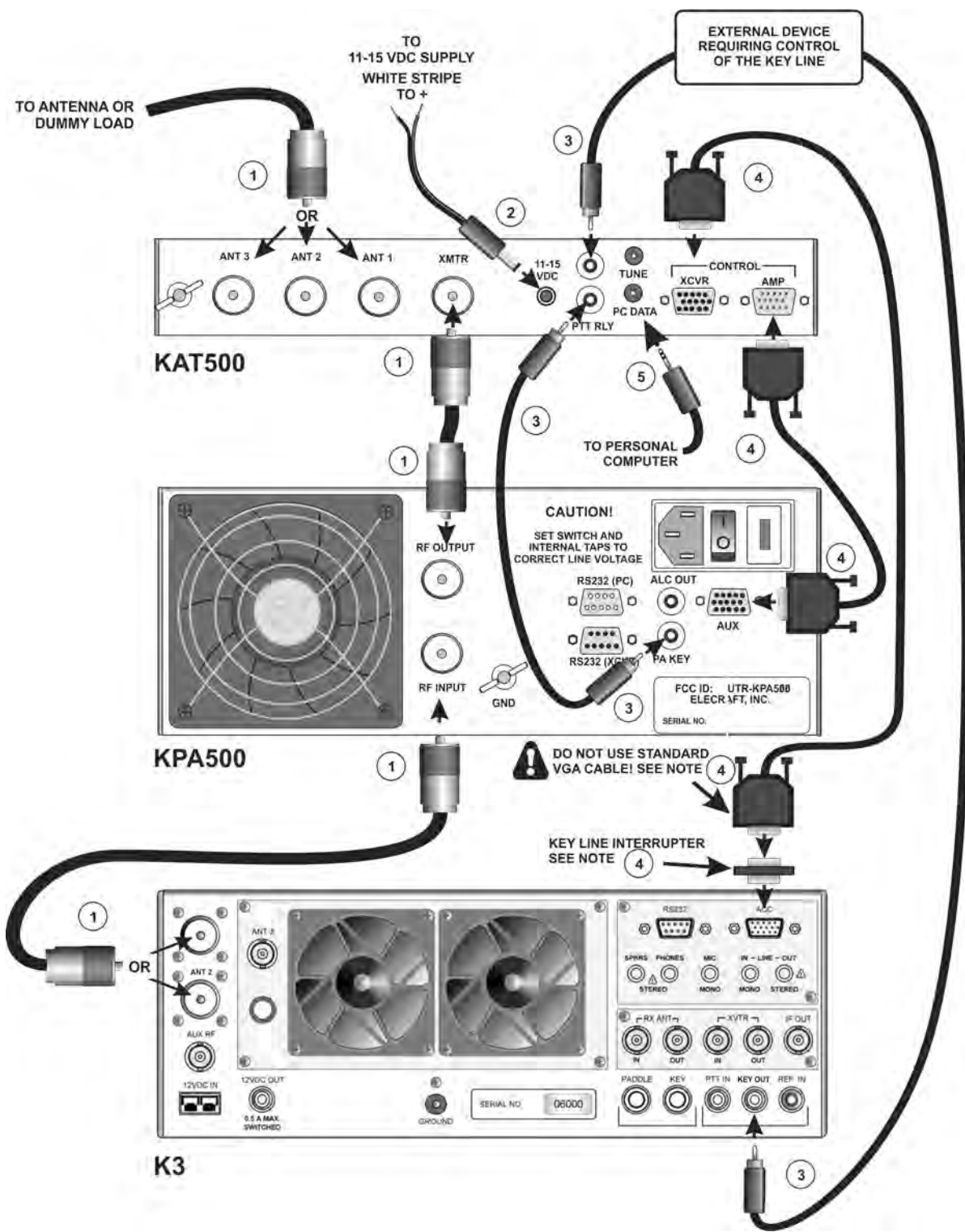

Figure 2. Cabling Diagram: Elecraft K3, KPA500 and KAT500 Using DB15 Interface Cables with Separate Key Line.



## General Cabling Requirements

The KAT500 works well with equipment other than the Elecraft K3 transceiver and KPA500 amplifier. Figure 3 shows the basic cabling required to work with any transceiver or transceiver and amplifier combination. See notes below for details about each cable.

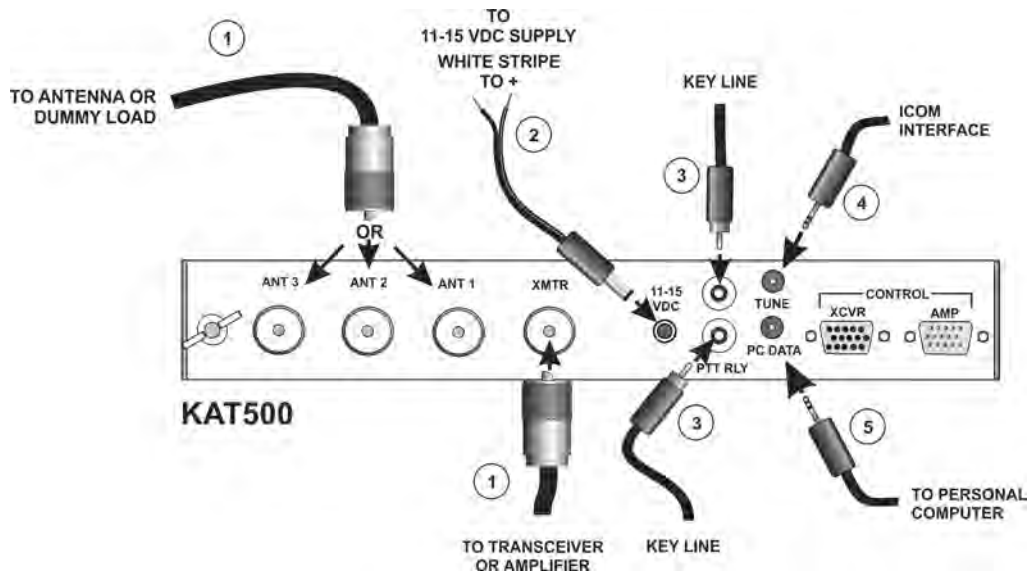

Figure 3. General Cabling Requirements.

- ① 50-ohm coaxial RF cables with PL-259 connectors. When using a transceiver with multiple antenna outputs such as the K3, be sure the correct antenna connection is selected. The KAT500 allows up to three antenna connections, selected from the front panel (See *Operation*, pg 8).
- ② Two wire power cable with a female 2.1 mm coaxial connector (supplied). Connect to the station 11 to 15 VDC power supply with the white striped lead to the positive terminal.
- ③ Power Amplifier Key cables with RCA connectors (one cable supplied). These cables inhibit the amplifier to avoid applying excessive RF power while the KAT500 is tuning. You may add other equipment that requires the amplifier be inhibited in series with this circuit at any point. The circuit inside the KPA500 is a simple relay closure, so it does not matter which connector goes into each jack.
- ④ Optional user-supplied cable with a 3.5 mm T-R-S jack that allows Icom transceivers using the AH-4 protocol to control the KAT500 via a user-supplied cable.
- ⑤ Computer interface cable with a T-R-S connector at one end and USB connector at the other end supplied with the KAT500 (supplied). Not required for normal operation, but used for controlling the KAT500 from a personal computer, customizing the KAT500's operation or for updating firmware (see *Utility Program* on page 12).

## Interface Cable Wiring

### *DB15 Interface Cable*

The DB15 Interface cable may be ordered from Elecraft (order E850463). Optionally, you can construct your own cable using male and female DB-15 connectors wired as follows.

CONNECTOR PINS		SIGNAL
2	2	AUXBUS
3	3	BAND 1
5	5	GND
9	9	BAND 2
10	10	PTT (See Note)
11	11	Inhibit
12	12	GND
13	13	BAND0
14	14	BAND3
15	15	ALC (Normally not used. See your KPA500 Owner's Manual)

**NOTE:** If you have devices that need access to the PA Key line (e.g. SteppIR controllers, etc.), leave pin 10 open and use the external key line cable (see Figure 2, cable ③). If you purchased the KPAK3AUX cable set which includes the DB15 Interface Cable, a key line interrupter is provided that plugs in between the cable and the K3 to interrupt the pin 10 circuit without modifying your cable.

### *Icom AH-4 Interface*

This cable uses a 4-pin Icom Molex connector at one end and a 2.1 mm coaxial power connector and a 3.5mm T-R-S plug at the other end. The cable is wired as follows:

MOLEX CONNECTOR	SIGNAL	T-R-S CONNECTOR	POWER CONNECTOR
Pin 1	Key	Tip	NC
Pin 2	Start	Ring	NC
Pin 3	+12 VDC	NC	Center
Pin 4	Ground	Shield	Outer Shell

**NOTES:** Pin 1 is at the triangular end of the Molex connector. NC = No connection.

## Operation

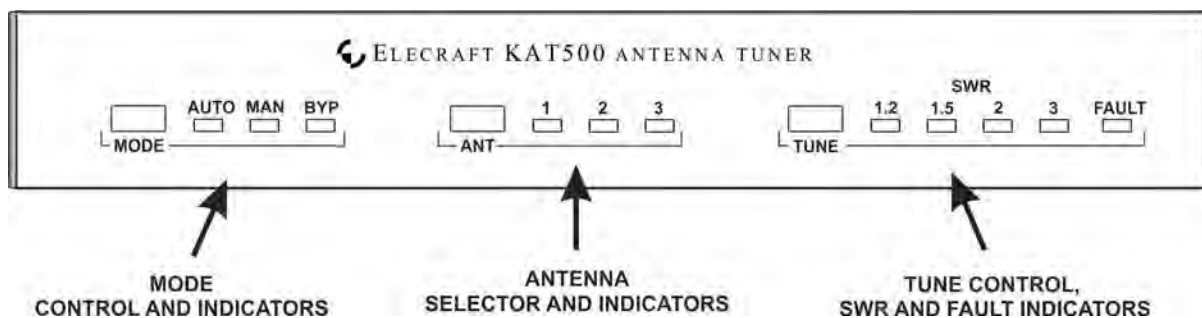

Figure 4. KAT500 Front Panel Controls.

## Tuning

**⚠ IMPORTANT:** If you are using the KAT500 with an Elecraft K3 transceiver connected using DB15 cables as shown in Figure 1 or Figure 2, you must apply power to the KAT500 before turning the K3 on. If you turn the K3 on before applying power to the KAT500 the K3 will not be able to initialize correctly.

- Be sure the KAT500 is connected to your station equipment as shown under *Cabling* (pg 3).
- Apply power to the KAT500. It will turn on automatically.
- Tap MODE, if necessary, to select AUTO.
- Tap ANT to select the antenna you wish to use.
- Tap TUNE. AUTO will begin to flash.
- Apply RF power between 10 and 100 watts. **The KAT500 will not respond to less than 10 watts of RF drive.** Most transceivers produce RF in this range when driving an external amplifier. The KAT500 will open the key line to disable the external amplifier so the transceiver drives the KAT500 directly during the tune cycle. You will hear relays operating until the selection of inductance and capacitance has been found that yields a low SWR. (See *Fault Conditions* on pg 11 if the FAULT LED lights.) An approximate SWR is indicated on the TUNE LEDs. The KAT500 Utility program (pg 12) may be used to display a more accurate SWR reading.

After successfully tuning, the KAT500 stores the settings and antenna selected in memory from which it is recalled almost instantly when returning to that frequency later. The entire spectrum from 1.8 through 60 MHz is divided into frequency segments and the tuning information is stored for each segment. Since retuning is normally required over a narrower frequency range on the lower frequencies to maintain a low SWR, the lower frequencies have narrower segments assigned as follows:

- Below 3 MHz the segments are 10 kHz wide.
- From 3 MHz through 26 MHz the segments are 20 kHz wide.
- From 26 MHz to 38 MHz the segments are 100 kHz wide.
- From 38 MHz to 60 MHz the segments are 200 kHz wide.

In AUTO mode, if you QSY such that the SWR rises above 1.8:1 the KAT500 will automatically retune when you transmit on the new frequency. The KAT500 will open the key line to disable your amplifier briefly until the tune cycle is completed. The new frequency and settings are stored in memory.

If the SWR measured by the KAT500 is 1.2:1 or below, the KAT500 automatically switches to bypass in that frequency segment.

If the SWR remains above 2.0:1 after a tune operation, the KAT500 will hold the key line open to protect your amplifier from the high SWR load.

The SWR limits that initiate an automatic TUNE in AUTO, switches the KAT500 to bypass or which causes the KAT500 to hold the key line open to protect the amplifier can be changed using the Utility Program. See *KAT500 Configuration* (pg 12) for details.

You can prevent automatic tuning by selecting the MAN (manual) mode. In MAN, the KAT500 will automatically choose a new tuner setting based on the band and antenna selected, but you must tap TUNE and then apply RF power to initiate a tuning operation if needed.

BYP mode bypasses the KAT500 completely, routing the RF input to the selected ANT connection.

**i OPERATING TIP:** If you want quick QSY capability, do a tune operation as described above on your favorite frequencies, using each antenna you might select. This stores the correct settings in the KAT500 memory so they will be recalled almost instantly when you return to that frequency. If you have changed your antenna system, it may be helpful to use the KAT500 Utility program to erase the previously stored data before tuning again to establish the new settings (see *Utility Program*, page 12)

### ***Fine Tuning***

If a tune operation results in an undesirably high SWR, you can immediately order another tuning cycle by tapping TUNE again within 5 seconds. The KAT500 will repeat the tune operation starting with the settings just found, but using finer step sizes in L and C values. This may result in a lower SWR. The new values are stored and will be used when returning to this frequency.

You can also manually adjust the L and C values using the KAT500 Utility Program (page 12). Load the Utility program, click on the OPERATE tab and then adjust the L and C values using the radio buttons or up and down arrows. When finished, click on MEMORIZE to store the new settings.

### ***Cancel Tuning***

Tap TUNE to cancel a tune command.

### ***Alternate Tuning Commands***

A TUNE command can be initiated through the RS232 port using the KAT500 Utility program. Load the Utility program, click on the OPERATE tab and then click on TUNE.

You can initiate a TUNE command through the rear panel TUNE jack (see Figure 3) with a transceiver using the AH-4 protocol or by momentarily shorting the ring to ground.

## Bandswitching

Some non-Elecraft amplifiers may be damaged if the KAT500 opens the key line while the amplifier is producing full RF output. This can happen when changing bands because the KAT500 senses the frequency of the RF signal, opens the key line, and then switches to the settings for that frequency from memory or initiates a tune operation.

The KPA500 amplifier is designed to have the key line interrupted while producing full output without damage. The DB15 interface cable between the K3, KAT500 and KPA500 (Figure 1 cable (3) or Figure 2 cable (4)), ensures that the KPA500 amplifier and KAT500 change bands at the same time as the K3.

### **CAUTION:**

**When using a non-Elecraft amplifier, change bands as follows to avoid damage to your amplifier.**

- **Place the amplifier in standby.**
- **Switch the transceiver or transmitter to the new band.**
- **If needed, manually switch the amplifier to the new band.**
- **If your amplifier requires manual tuning, connect it to a suitable dummy load. (You can attach the dummy load to one of the KAT500 antenna connectors, switch the KAT500 to **BYP** and select that connector with the **ANT** switch.) Tune up your amplifier into the dummy load per the manufacturer's instructions. Return the mode to **AUTO** when finished.**
- **Generate a CW signal from your transceiver or transmitter between 20 and 100 watts. This will allow the KAT500 to change bands, change antennas, if required, and switch to the tuning values for that frequency stored in memory or perform a tune cycle, if needed.**
- **Switch the amplifier from standby to operate.**

## Turning the KAT500 Off

Hold **MODE** or remove power to switch the KPA500 off. When off, **ANT 1** is automatically selected. Unused antenna connections are not grounded but the KAT500 contains a bleeder resistor across each antenna input.

## Fault Conditions

A fault will occur if:

- The RF drive power exceeds 110 watts during a **TUNE** operation. This protects the relays from damage due to excessive RF power while switching. If this fault occurs, be sure you have the **PA Key** circuit installed, either through the DB15 interface cable or using separate key line cables (see *Cabling*, pg 3).
- The impedance of your antenna is outside of the tuning range so an acceptable **SWR** cannot be found.

Reset the fault by tapping the **TUNE** switch or cycling power off, then on again with the **MODE** switch.

# Utility Program

To use the Utility Program you will need:

- A personal computer.
- The KAT500 Utility Program available free from Elecraft at [www.elecraft.com](http://www.elecraft.com).
- The RS-232 cable with a USB connector supplied with your KAT500.

Connect your computer to the KAT500 using the interface cable connected to the PC DATA jack and load the Utility Program. Click on the PORT tab and select the port your computer is using to communicate with the KAT500. Click on TEST COMMUNICATIONS and you will see a pop-up stating that the Utility program is communicating with the KAT500 if everything is working properly.

Detailed operating instructions for the Utility program are provided in the Utility Help screens.

## KAT500 Configuration

You can configure the KAT500 to best support your installation. Click on the Utility program CONFIGURATION tab and then on the Per Band Configuration button. After making your choices, click on the APPLY button at the bottom.

### *Antennas*

You can select which antenna connectors are active (Enabled) on each band. Antenna connectors are disabled by clicking on the check mark to clear it. Disabling antenna connectors will cause them to be skipped over when cycling through the options with the front panel ANT switch or in the Utility Operate tab. You can also select which ANT connector you prefer to use on each band and it will be automatically selected when you return to that band. You can change the selection to any other antenna connector, using provided it has not been disabled.

### *Thresholds*

You can set the SWR thresholds above which a tuning cycle will be started in AUTO mode, or below which the KAT500 will automatically switch to bypass. Also, you can set an SWR threshold at which the key line will not close to enable the external amplifier to protect it from excessive SWR.

These thresholds can be set the same for all bands, or individual values can be entered for each band.

### *Memories*

You can erase all of the stored tuning memory data for the entire KAT500, or just the memories associated with a particular ANT selection and band.

### *Saving Configuration*

You can save the configuration to a file on your computer so that you can restore it quickly without needing to re-enter the data.

## Parameter Initialization (EEINIT)

It is possible, though rare, for parameters to become altered in such a way as to prevent the firmware from running correctly. If you suspect this, you can reinitialize parameters to defaults, then restore a previously-saved configuration (or restore the configuration manually using the utility program).

1. Click on the Command Tester tab.
2. Type EEINIT;
3. Restore your configuration, either from a previously-saved configuration file or manually as described under KAT500 Configuration above.

## Updating Firmware

Although the KAT500 is shipped with current firmware installed, from time to time updated and improved firmware may become available.

To update firmware, connect your KAT500 to your computer and launch the KAT500 Utility program.

Updated firmware may be obtained in two ways.

1. Click on Firmware tab and then the Click on Copy Firmware Files from Elecraft to download the latest production released firmware or,
2. Download the new file from the Elecraft web site manually and place it in a local folder, then click on Browse... to locate the folder on your computer. This is the way to access the latest Beta firmware available from Elecraft.

To install new firmware in your KAT500, click on the utility Send Firmware to the KAT500 button to start the transfer. Follow any on-screen instructions.

Be sure to check the notes supplied with the new firmware. They may include changes that affect the instructions in this manual.

If you don't have Internet access, you can obtain a firmware upgrade on CD. If you don't have a computer, you can send your KAT500 to Elecraft to be upgraded. See *Customer Service and Support*, pg 1.

# Kit Assembly Procedure

## Preventing Electrostatic Discharge Damage

Sensitive components in your KAT500 may be damaged by Electrostatic Discharge (ESD) in any location or climate unless you take specific steps to prevent such damage. Many components can be damaged by static discharges of only a few volts: far too little for you to notice.

ESD damage may not be apparent at first. The damaged components may not fail completely. Instead, the damage may result in below-normal performance for an extended period of time before you experience a total failure.

We strongly recommend you take the following anti-static precautions (listed in order of importance) to ensure there is no voltage difference between the components and any object that touches them:

- Leave ESD-sensitive parts in their anti-static packaging until you install them. The packaging may be a special plastic bag that allow static charges to flow harmlessly over their surface, or the component's leads may be inserted in conductive foam that keep them at the same potential. Parts which are especially ESD-sensitive are identified in the parts list and in the assembly procedures.
- Wear a conductive wrist strap with a series 1-megohm resistor that will constantly drain off any static charge that accumulates on your body. If you do not have a wrist strap, touch a ground briefly before touching any sensitive parts to discharge your body. Do this frequently while you are working. You can collect a destructive static charge on your body just sitting at the work bench.

### **WARNING**

**DO NOT attach a ground directly to yourself without a current-limiting resistor as this poses a serious shock hazard. A wrist strap must include a 1-megohm resistor to limit the current flow. If you choose to touch an unpainted, metal ground to discharge yourself, do it only when you are not touching any live circuits with any part of your body.**

- Use a grounded anti-static mat on your work bench.
- If you choose to use a soldering iron to work on your KAT500 for any reason, be sure your iron has an ESD-safe grounded tip tied to the same common ground used by your mat or wrist strap.

## Tools Required

1. #0 and #1 size Phillips screwdrivers. Use the screwdriver that best fits the screw in each step. To avoid damaging screws and nuts, a power screwdriver is *not* recommended.
2. Needle-nose pliers.

The following tools are strongly recommended:

1. ESD wrist strap.
2. Static dissipating work pad.



## Assembly Procedure

- Before starting construction, do a complete inventory, comparing the parts in your kit with the parts list in Appendix A, to familiarize yourself with all of the parts and to ensure the kit is complete. If any parts are missing contact Elecraft for a replacement (see *Customer Service and Support*, page 1).
- Taking ESD precautions remove the printed circuit board from its ESD-safe envelope and install six 2-D fasteners as shown in Figure 5. Be careful not to disturb any of the inductors on the top side, especially the air wound coils, or the position of the resistor mounted on the bottom.

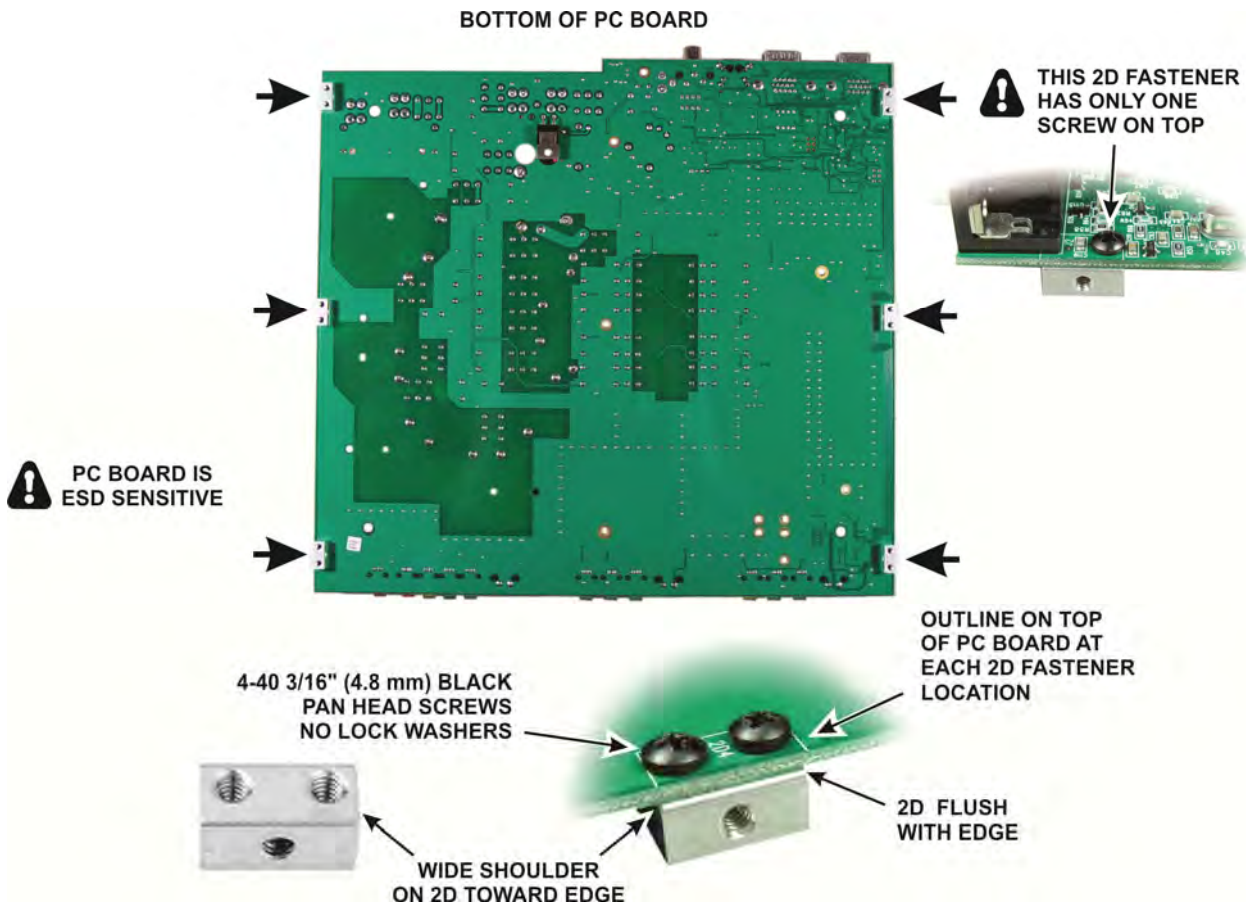

Figure 5. Installing the 2D Fasteners.

Install the three pairs of standoffs on the pc board shown in Figure 6. Do not use lock washers. The standoffs alone establish the right height.

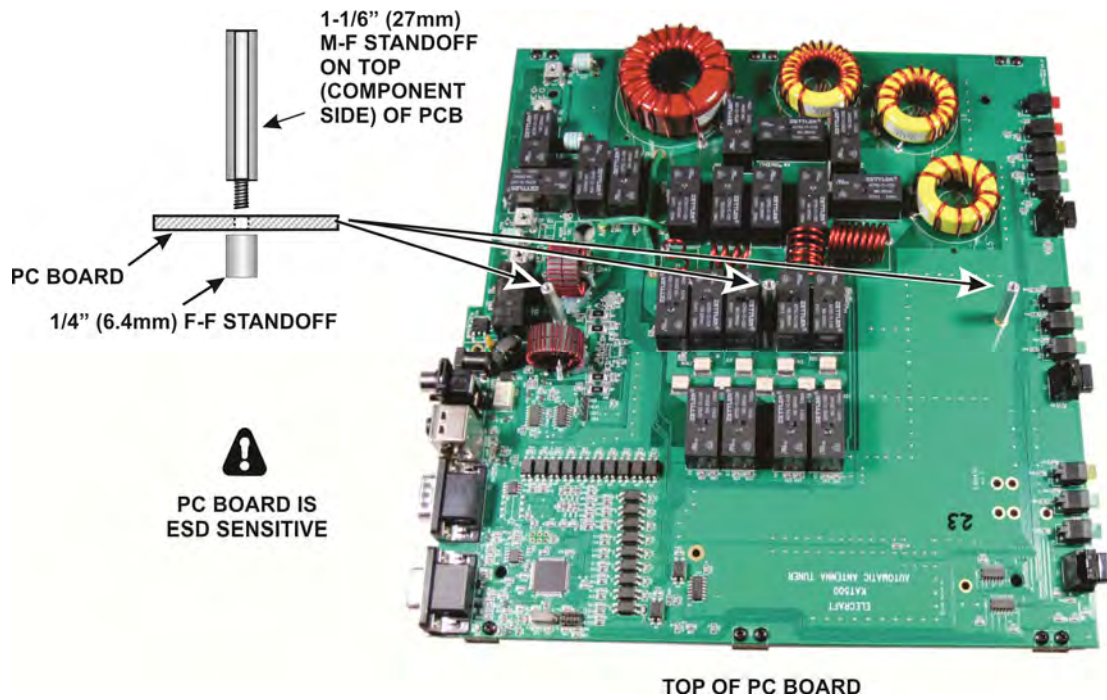

Figure 6. Installing Standoffs on the PC Board.

Locate the outline marked LB1 on the pc board. It is on the connector edge of the board next to the power connector (see Figure 7).

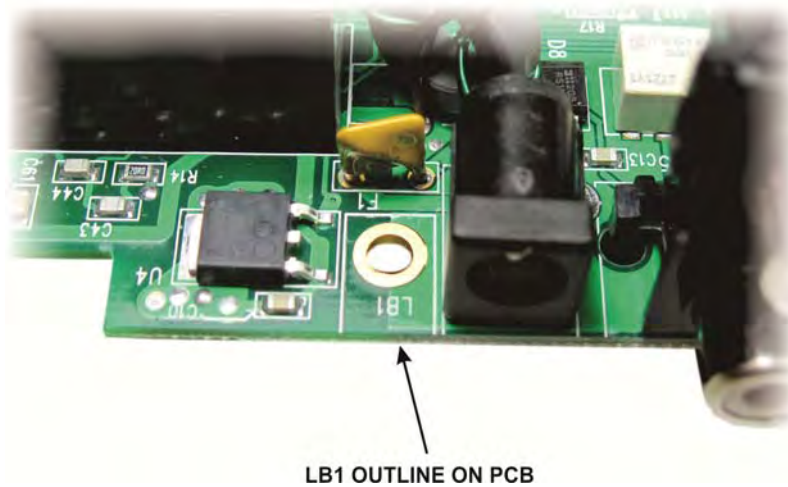

Figure 7. Angle Bracket LB1 Mounting Location

Mount the angle bracket at LB1 on the pc board as shown in Figure 8. Note that it has a long and short side. Be sure the long side is against the pc board as shown.

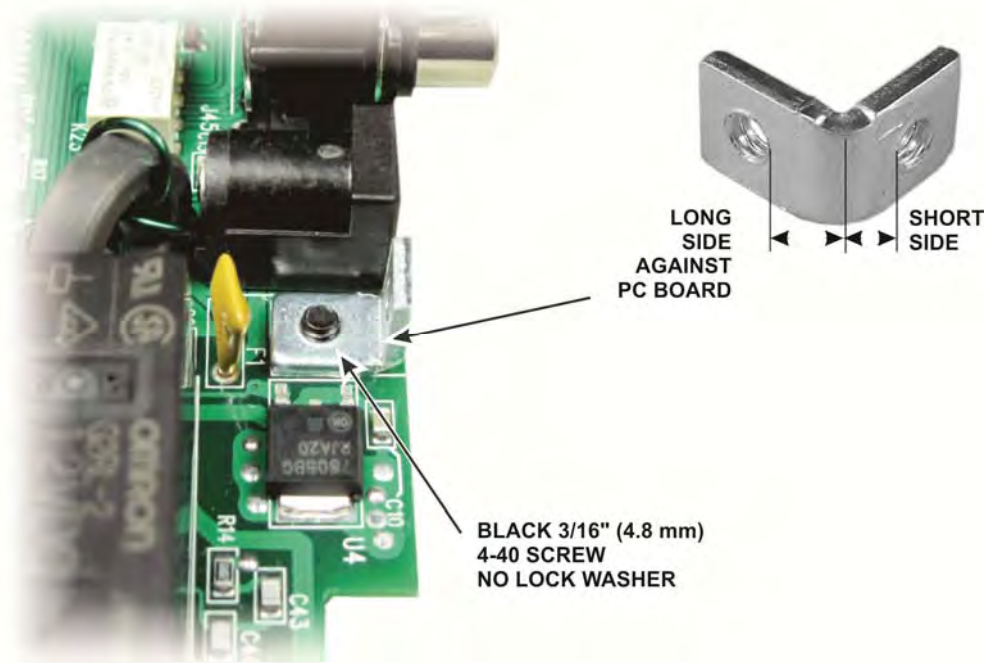

Figure 8. Installing the Angle Bracket.

Locate the bottom cover. It is the same size as the top cover, but you can identify it by the hole pattern. Check the **inside** surface and remove any tape or other residue to ensure clean, bare metal at the locations shown in Figure 9. This is important for proper grounding of the enclosure panels.

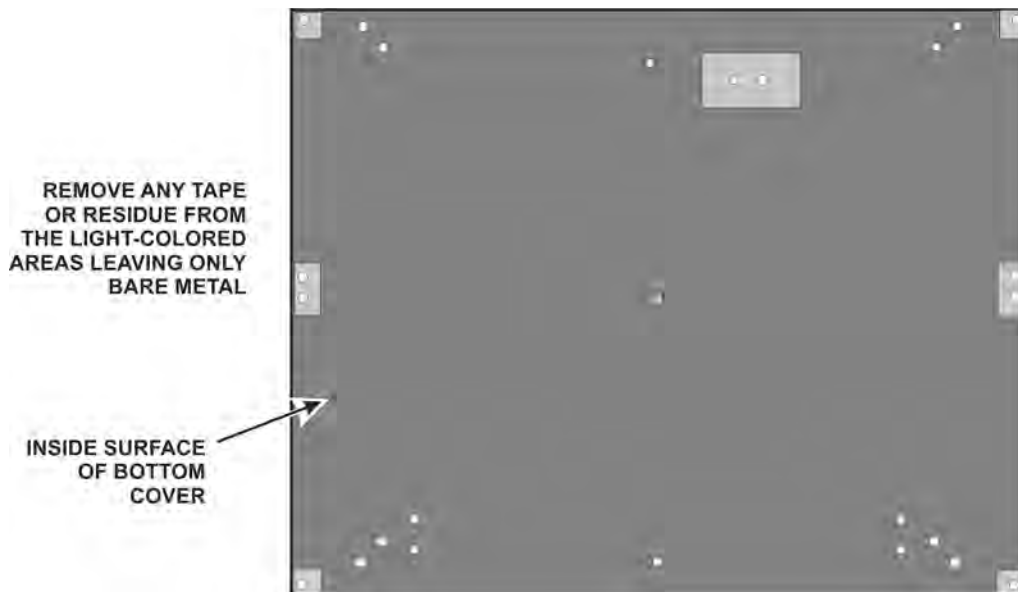

Figure 9. Preparing Bottom Cover for Installation.

☐ Turn the bottom cover over and place the four self-stick feet on the cover in the locations shown in Figure 10. Do not cover any of the holes in the bottom cover with the feet. The screw hole indicated will be used in the next step.

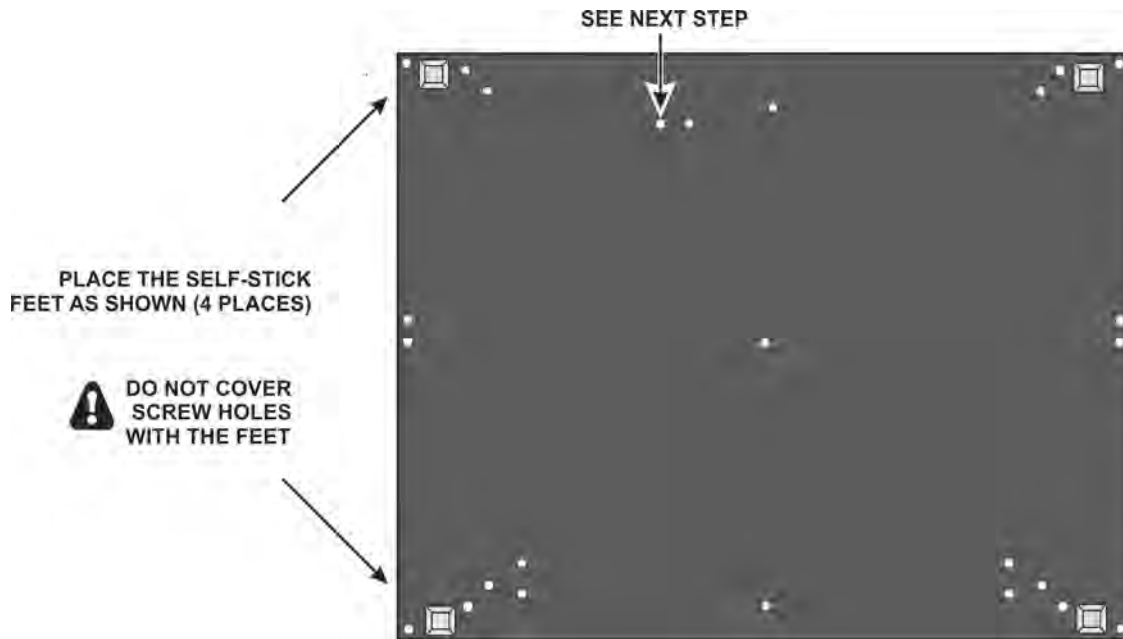

Figure 10. Placing Feet on the Bottom Cover.

☐ Install a screw, lock washer and nut in the hole indicated in Figure 10 as shown in Figure 11 with the screw head on the outside of the bottom cover. This hole is unused. The hardware is provided to fill it.

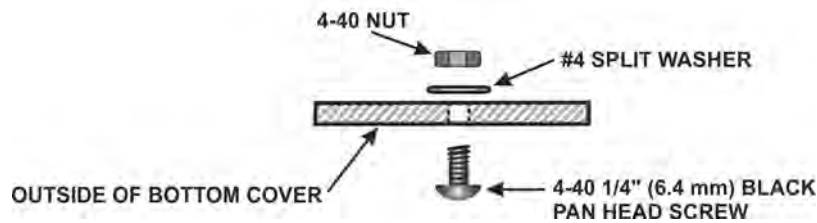

Figure 11. Installing Hardware on Bottom Cover.

☐ Place the circuit board component side down on your work table and attach the thermal pad to resistor R6 as shown in Figure 12.



Figure 12. Placing Thermal Pad on R6.

□ Attach the bottom cover as shown in Figure 13. Note that the bottom cover only fastens to one of the two screw holes in each of the 2D fasteners mounted at the corners of the circuit board. The remaining screw holes in those 2D fasteners will be used to secure the front and rear panels. When positioning the bottom cover, be sure the open hole shown in Figure 13 lines up with the hole in the tab for R6 mounted on the circuit board.

**⚠ NOTE:** When assembling the cabinet pieces, start each screw in the threads before tightening any screws. When adding more cabinet sections in future steps, you may need to loosen the screws for other sections so they can be adjusted slightly as needed to fit properly. Once you have done that and finished assembling your KAT500, you can remove and replace individual cabinet sections easily without further adjustments.

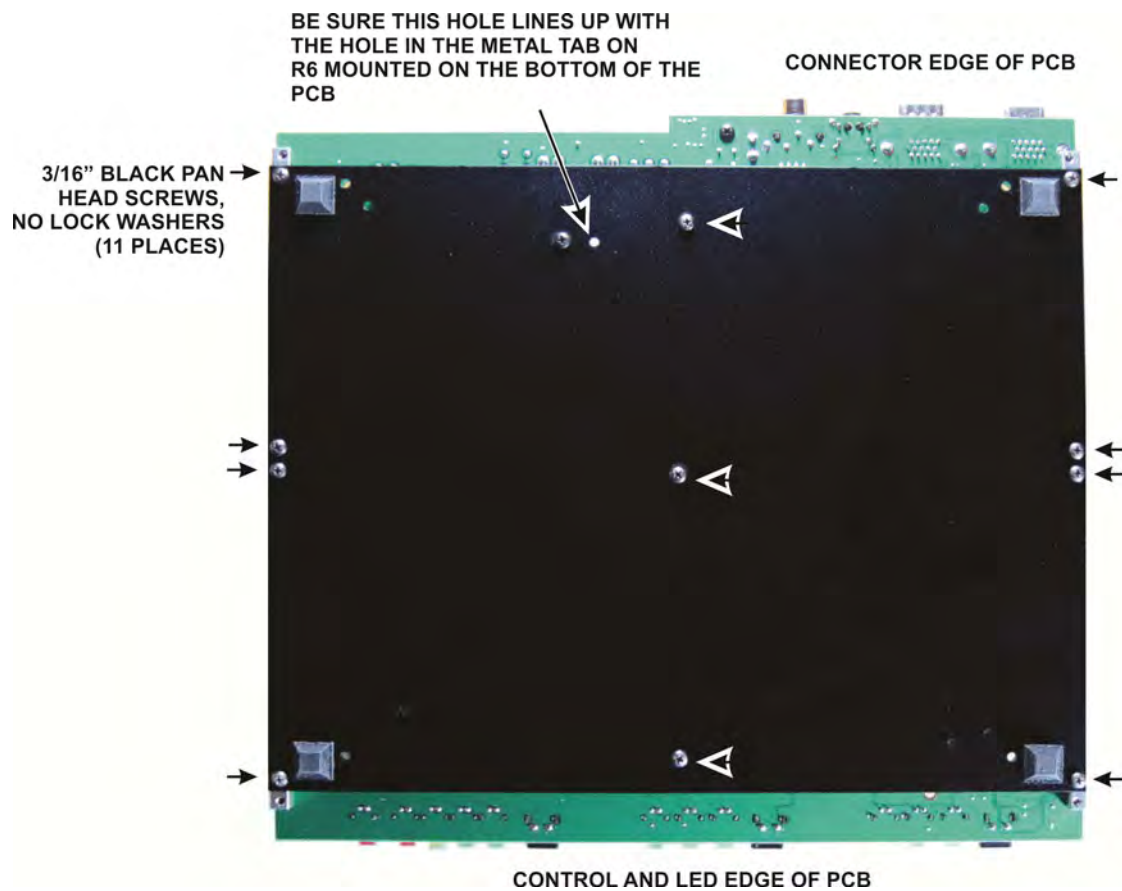

Figure 13. Installing the Bottom Cover.

- Turn the assembly over so the pc board is on top and install the R6 mounting hardware as shown in Figure 14 to secure R6 against the bottom cover.

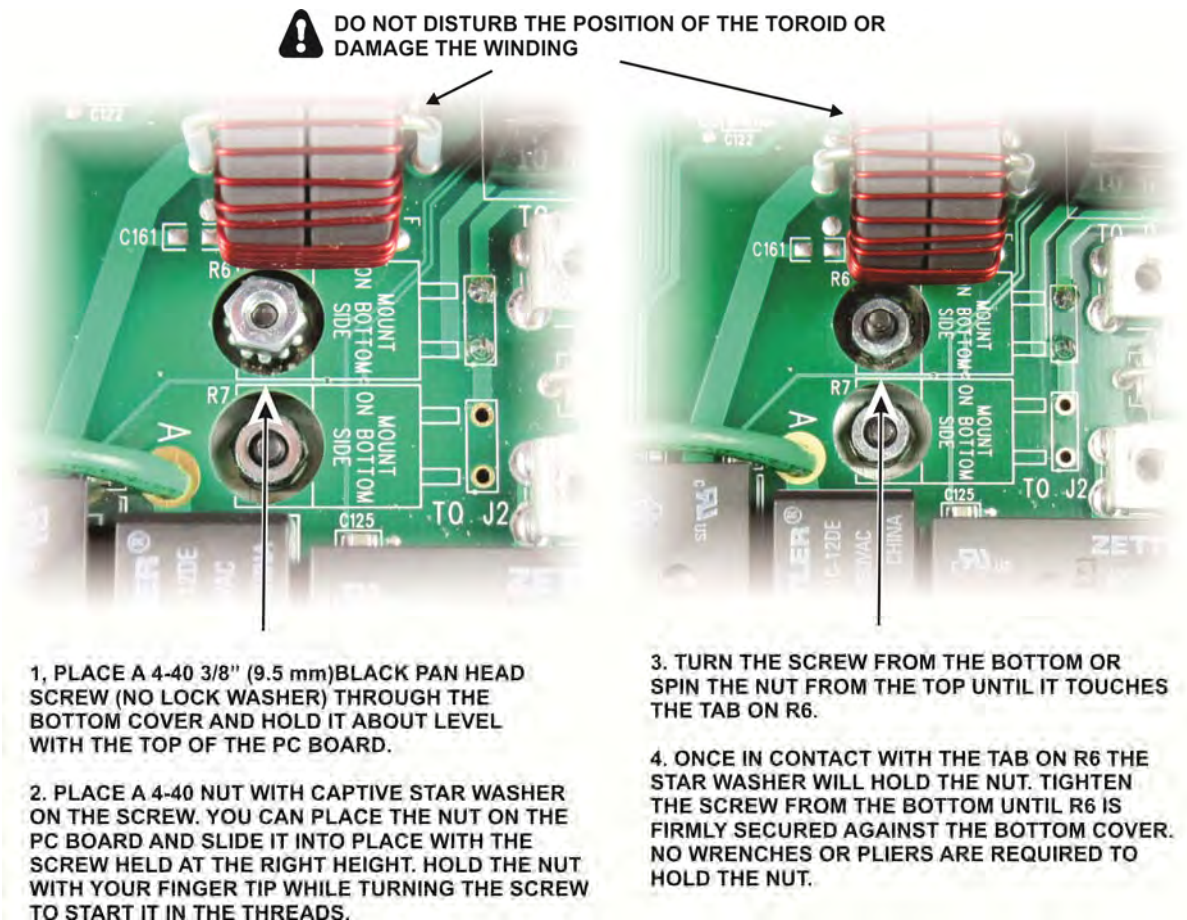

Figure 14. Installing the R6 Mounting Hardware.

- Set the pc board and bottom cover assembly aside temporarily in a safe place.
- Locate the rear panel and the four SO-239 connector assemblies. **Leave the SO-239 connector assemblies in their packages until needed and do not bend or move the wire attached to each connector. The wires have been carefully pre-formed to fit in the KAT500.**

- Inspect the inside surface of the rear panel and remove any tape or residue to provide a clean metal surface where shown in Figure 15.

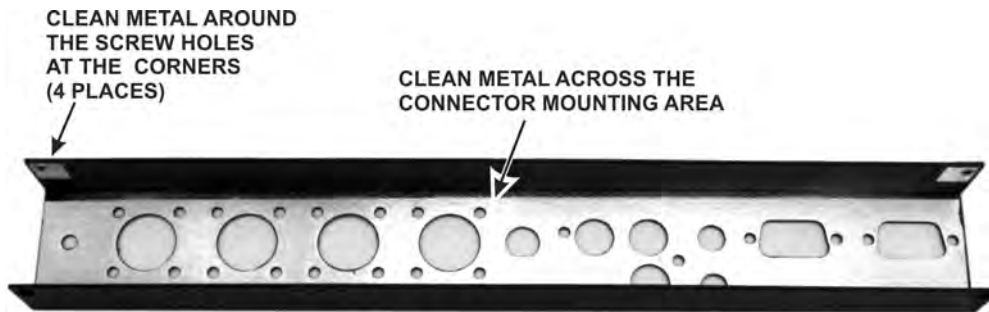

Figure 15. Preparing the Rear Panel.

- Remove the protective backing from the serial number label and press it onto the rear panel as shown in Figure 16. Be careful not to cover the screw holes or lettering on the rear panel.



Figure 16. Attaching Serial Number to Rear Panel.



□ Install the XMTR SO-239 connector in the rear panel opening marked XMTR as shown in Figure 17. Take care not to bend the wire or move the solder lug. Place the flange of the connector inside the rear panel, and orient the connector so the lug on the wire points toward the ANT1 connector opening as shown.

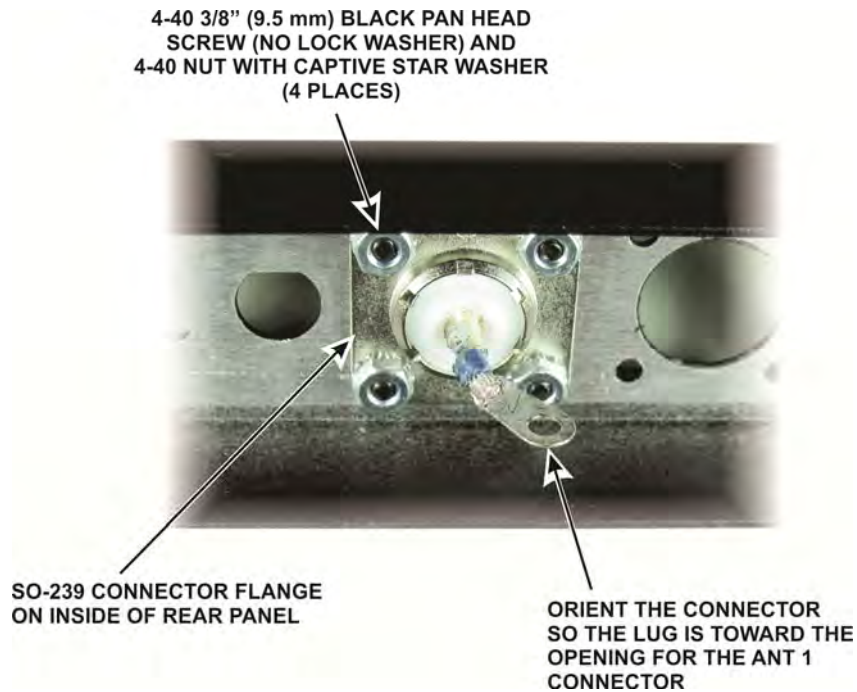

Figure 17. Installing the XMTR SO-239 Connector in the Rear Panel.

□ In the same manner, install the remaining SO-239 connectors on the rear panel, taking care to orient the connectors so the leads are as shown in Figure 18 and with the connector flanges on the inside of the rear panel.

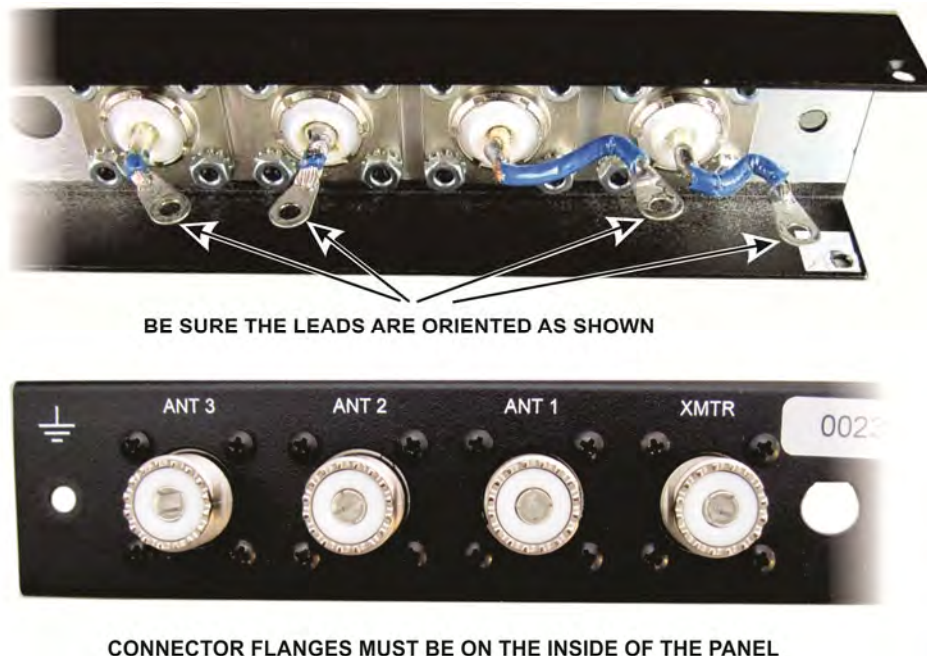

Figure 18. SO-239 Connectors Installed.

□ Mount the ground terminal at the end of the rear panel next to the ANT 3 connector as shown in Figure 19. Install the screw, lock washer and nut first and secure the nut so the screw cannot turn. Then add the two flat washers and the wing nut.

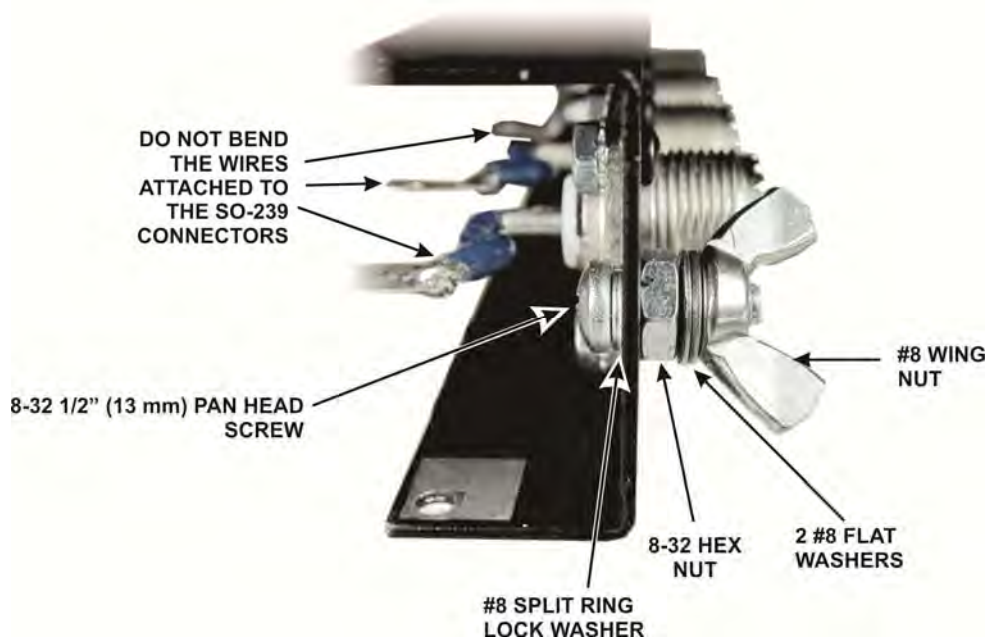

Figure 19. Installing the Ground Terminal.

□ Install the BNC hole cover in the opening next to the XMTR SO-239 connector as shown in Figure 20. Press the cover in until the ears on the plug lock it into place. This opening is “D” shaped. If needed, cut the plug section as shown to fit in the hole.

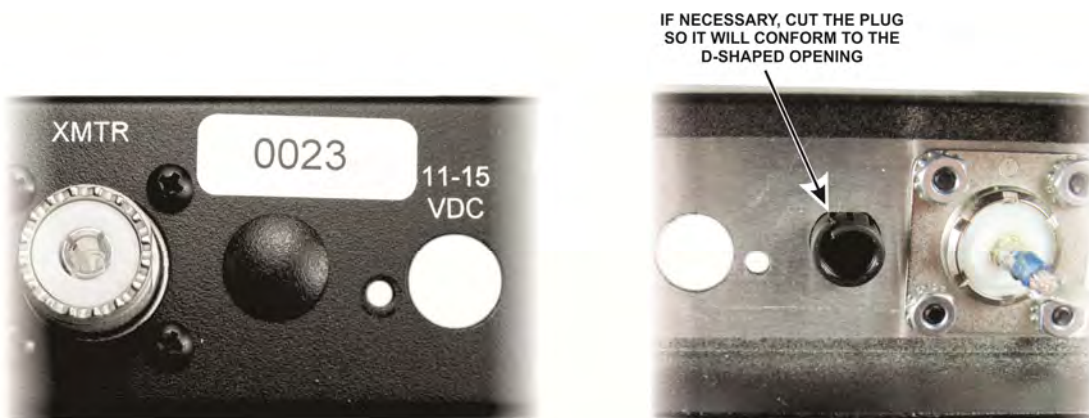

Figure 20. Installing the BNC Hole Cover.

☐ Position the rear panel on the pc board/bottom cover assembly you assembled earlier as shown in Figure 21.

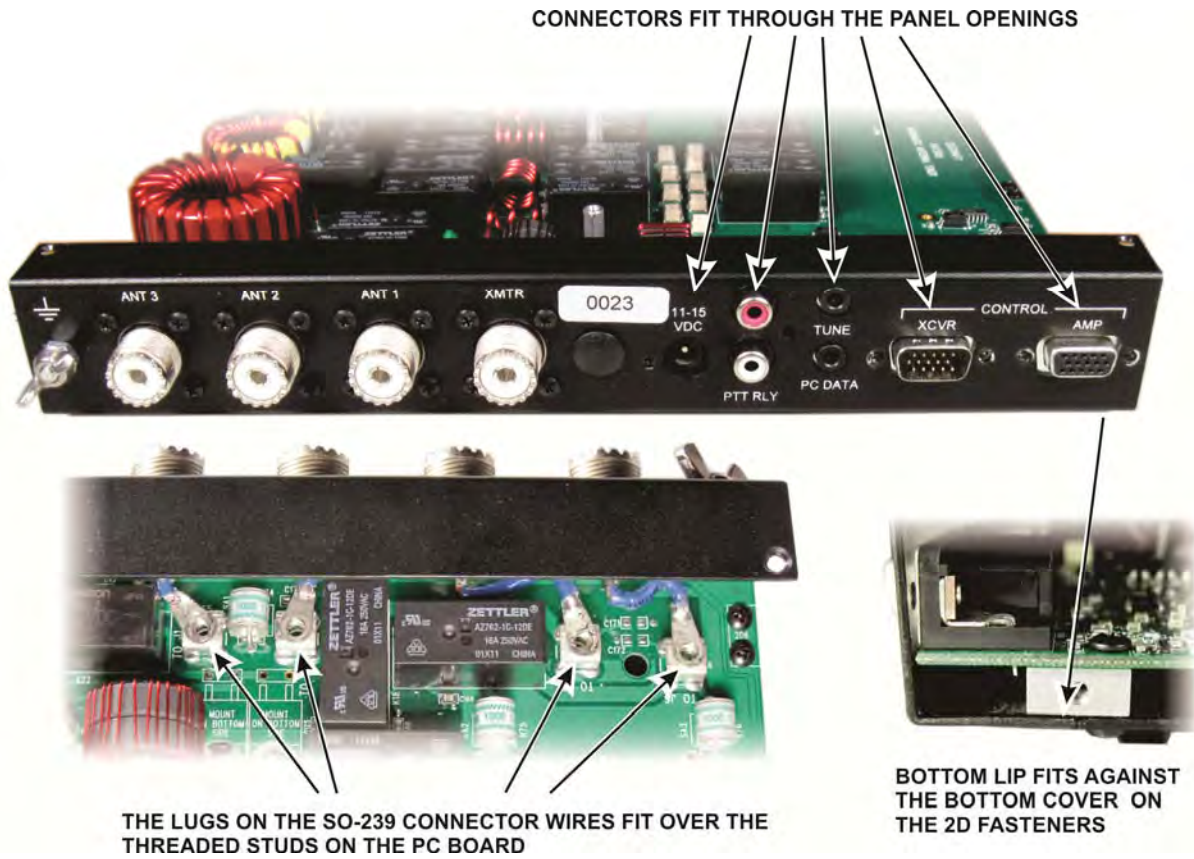

Figure 21. Positioning the Rear Cover on the PC Board and Bottom Cover Assembly.

☐ Begin securing the rear panel to the pc board assembly with four jack screw nuts on the XCVR and AMP connectors as shown in Figure 22.



**⚠ CAUTION: DO NOT OVER-TIGHTEN THE NUTS. IT IS EASY TO TWIST THE NUT OFF OF THE THREADED SHAFT.**

Figure 22. Installing Jackscrew Nuts on XCVR and AMP Connectors.

- Install the two pan head screws shown in Figure 23. **Stop turning the screw indicated when the head reaches the rear panel. It threads into plastic and the threads will easily strip.**



Figure 23. Installing Rear Panel Pan Head Screws.

- Attach the wires leading to each of the SO-239 connectors to the screw posts on the pc board as shown in Figure 24.

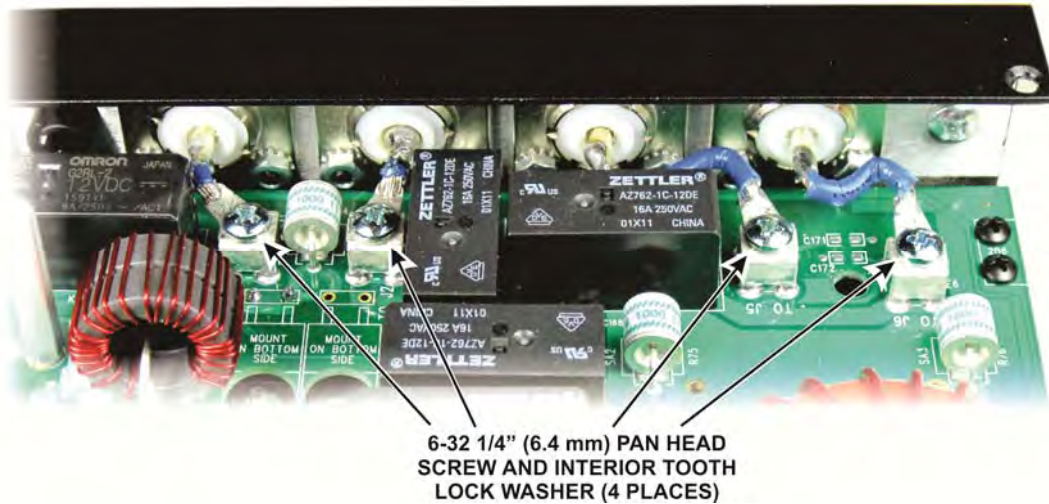
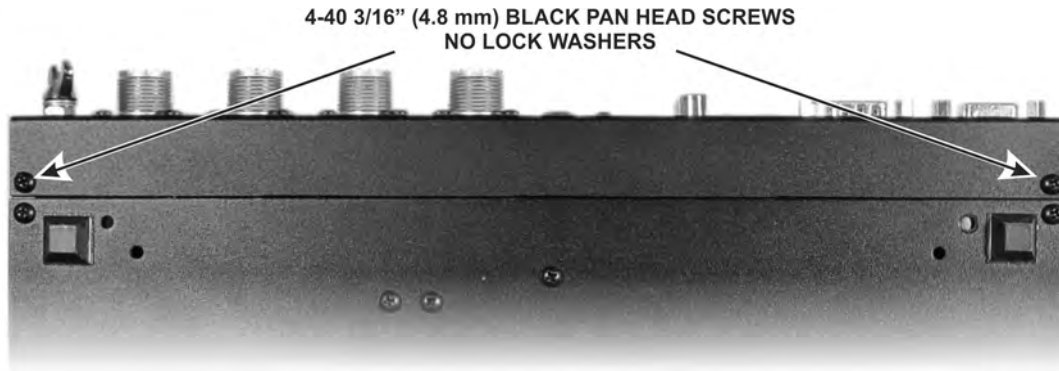

Figure 24. Securing SO-239 Wires to the PC Board Screw Posts.

Turn the assembly over and secure the bottom lip of the rear panel to the 2D fasteners as shown in Figure 25.



4-40 3/16" (4.8 mm) BLACK PAN HEAD SCREWS  
NO LOCK WASHERS

Figure 25. Installing Screws in Rear Panel Bottom Lip.

Install the four standoffs shown in Figure 26. The standoffs pass through large holes in the pc board and mount on the bottom cover as shown.

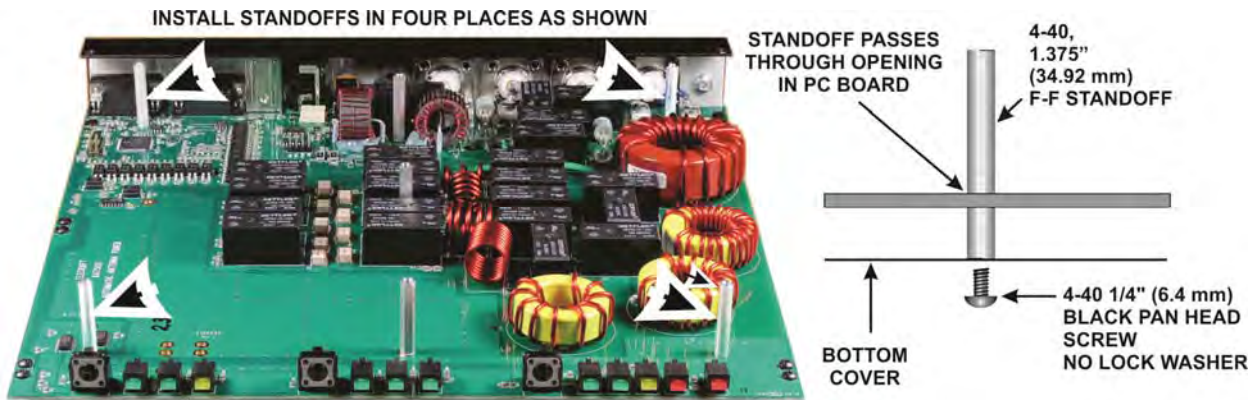

INSTALL STANDOFFS IN FOUR PLACES AS SHOWN

STANDOFF PASSES THROUGH OPENING IN PC BOARD

4-40, 1.375" (34.92 mm) F-F STANDOFF



BOTTOM COVER

4-40 1/4" (6.4 mm) BLACK PAN HEAD SCREW  
NO LOCK WASHER

Figure 26. Installing Through-Board Standoffs.

On the edge of the pc board that has the rows of LEDs, install key caps on the three switches (S1, S2 and S3) as shown in Figure 27. Be sure you orient the key caps horizontally (parallel with the pc board).

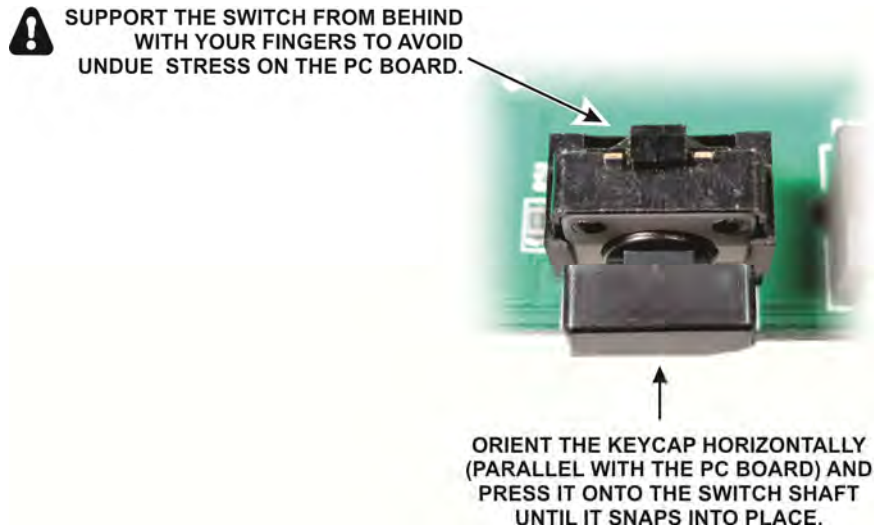

Figure 27. Installing Key Caps on the Switches.

Locate the front panel and inspect the inside surface around the four screw holes (see Figure 28). Remove any tape or residue to provide a clean metal surface.



Figure 28. Preparing the Front Panel for Installation.

Turn the KAT500 upside down on your table and mount the front panel as shown in Figure 29. Be sure that all of the LEDs and switches pass through the openings in the front panel.



Figure 29. Mounting the Front Panel.

- Set the KAT500 on its feet and confirm that all three switches operate smoothly and that all of the LEDs are in the front panel cutouts. The LEDs should protrude slightly so you can feel them by running your finger across the panel.
- Locate the side panels and clean any tape or residue from the areas around the screw holes on the inside surface as shown in Figure 30. Check and clean both side panels.

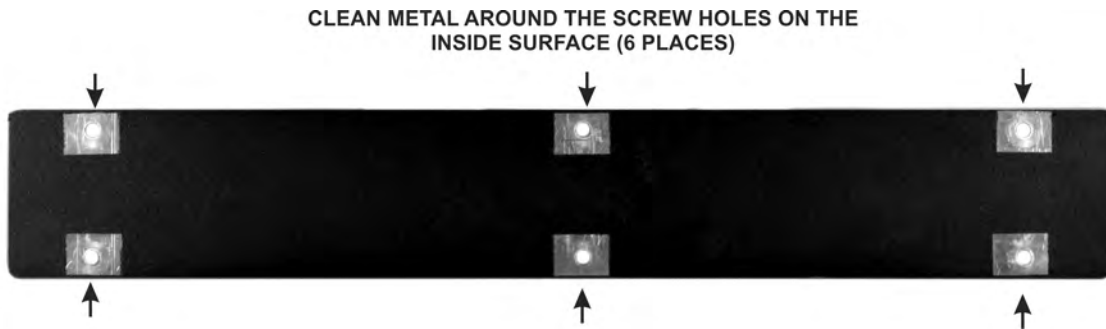

Figure 30. Preparing Side Panels for Installation.

- Place a side panel on the KAT500, lining up the three holes along the bottom with the 2D fasteners between the pc board and the bottom cover. Be sure all three holes line up. If they do not line up, turn the side panel over to line up the other three holes. Attach the side panel with three screws as shown in Figure 31 (1).
- Mount three 2D fasteners along the top edge of the side pane as shown in Figure 31 (2). Be sure the widest side is toward the side panel as shown. You may need to loosen the screws along the bottom edge to allow the panel to move to properly align the holes.

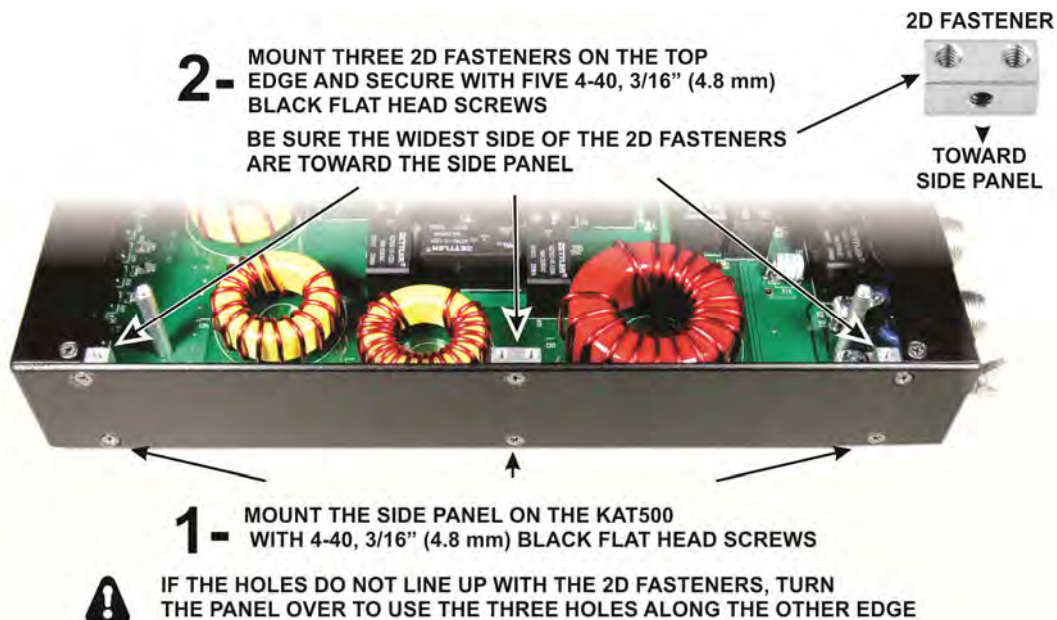

Figure 31. Installing the Side Panels.

- Install the second side panel in the same manner as the first.

In the following steps you will prepare and install the top cover. But before you do, check to ensure the screws inside the KAT500 are tight without over-tightening them:

- The 11 screws along the sides of the pc board (Figure 5, page 15).
- The four screws securing the SO-239 connector leads to the standoffs on the pc board (Figure 24, page 26).

Locate the top cover and clean any tape or residue from around the holes on the inside surface along the sides as shown in Figure 32. Note that not all of the screw holes have bare metal around them. Only those shown need to be checked.

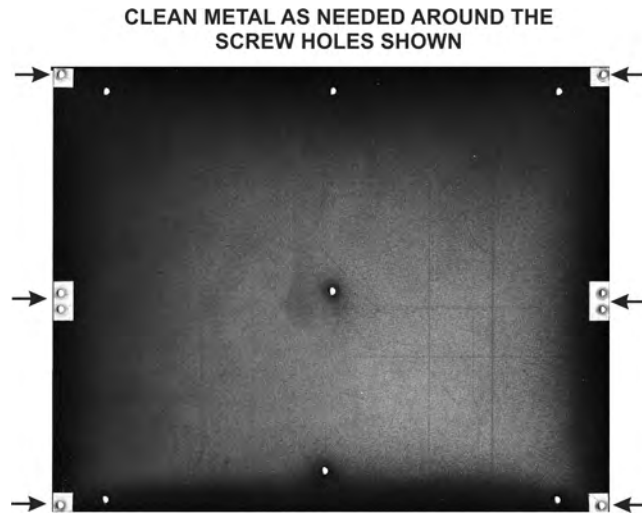

Figure 32. Preparing the Top Cover for Installation.



□ Place the top cover on the KAT500 and secure it as shown in Figure 33. If all of the screw holes do not line up, rotate it a half turn. It only fits one way. You may need to loosen some of the other enclosure screws for the cover to fit properly. That is normal. The top cover should fit flush with the surrounding panels. Once you have loosened and tightened the screws as needed for all of the panels to fit together, you will be able to remove and replace individual panels in the future, if needed, without having to repeat that process.

4-40 3/16" (4.8 mm) BLACK FLAT HEAD SCREWS WHERE INDICATED  
(15 PLACES)

**!** LOOSEN SURROUNDING PANEL SCREWS AS NEEDED TO ADJUST THE POSITION OF THE ADJACENT PANELS FOR A SMOOTH FIT. THE TOP COVER SHOULD BE FLUSH WITH THE SURROUNDING PANELS.



Figure 33. Installing the Top Cover.

**!** **IMPORTANT:** The enclosure screws, including all of the top cover screws, are important to the structural strength KAT500. Always be sure that all the screws are in place and tight.

That completes the assembly of your KAT500. Turn to page 3 for setup and operating instructions.

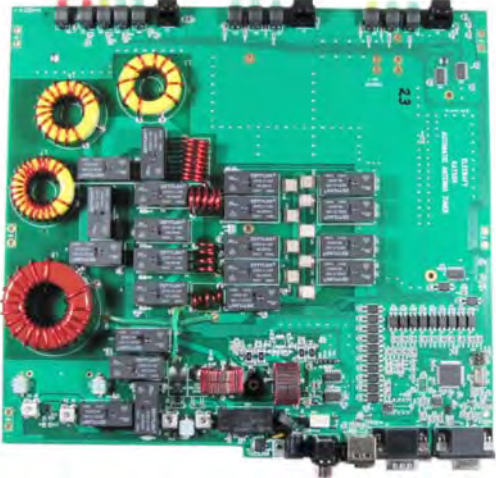

# Appendix A Parts List

## KAT500 Circuit Board

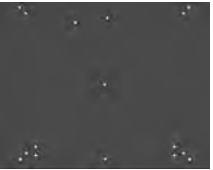

ILLUSTRATION	DESCRIPTION	QTY.	ELECRAFT PART NO.
	<p>KAT500 PCB Assembly</p> <p><b>⚠</b> ESD Sensitive. Do not remove from its ESD-Safe packaging without first taking ESD precautions (see page 14).</p>	1	E850566

## KAT500 Core Assembly – E850561

### *Wrapped Covers E850565*

ILLUSTRATION	DESCRIPTION	QTY.	ELECRAFT PART NO.
	Bottom Cover	1	E100437
	Top Cover	1	E100438

**Wrapped Panels E850564**





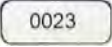

ILLUSTRATION	DESCRIPTION	QTY.	ELECRAFT PART NO.
	Front Panel	1	E100434SS
	Rear Panel	1	E100435SS
	Side Panel	2	E100436

**Serial Number Envelope E850549**

ILLUSTRATION	DESCRIPTION	QTY.	ELECRAFT PART NO.
	Serial Number Label	1	E980236

**Miscellaneous Bag E850562**



ILLUSTRATION	DESCRIPTION	QTY.	ELECRAFT PART NO.
	Lock washer, #4, Interior Tooth	1	E700010
	Lock Washer, #6, Interior Tooth	4	E700095
	4-40 Nut, Hex, Zinc	1	E700011
	8-32 Nut, Hex, Zinc	1	E700202
	4-40 Nut with Captive Star Washer	1	E700191
	Wing Nut, 8-32, Stainless Steel	1	E700193
	2-D Fastener	12	E100078
	L-Bracket	1	E700073
 (Typical)	4-40 Screw, 3/8" (9.5 mm) Black Pan Head	1	E700175
	4-40 Screw, 1/4" (6.4 mm) Black Pan Head	2	E700174
	4-40 Screw, 3/16" (4.8 mm) Black Pan Head	32	E700172
	4-40 Screw, 3/16" (4.8 mm) Black Flat Head	31	E700173

ILLUSTRATION	DESCRIPTION	QTY.	ELECRAFT PART NO.
 (Typical)	8-32 Screw, 1/2" (13 mm) Zinc Pan Head	1	E700192
	6-32 Screw, 1/4" (6.4 mm) Zinc Pan Head	4	E700281
	Lock Washer, #8 Split Ring	1	E700203
	Lock Washer, #4, Split Ring	4	E700004
	BNC Hole Cover	1	E980136
	Washer, #8 Flat	2	E700194
	1/2 X 1/2 (13 mm X 13 mm), Rubber Foot, Self-Adhesive	4	E700024
	Jackscrew Nut, 4-40	4	E700078
	Keycap, Rectangular	3	E980000
	Thermal Pad	1	E700002
 (Typical)	4-40 F-F Standoff, 1.375" (34.92 mm)	4	E700275
	4-40 F-F Standoff, 1/4" (6.4 mm)	3	E700026
	4-40 M-F Standoff, 1-1/16" (27 mm)	3	E700276



**⚠ IMPORTANT:** The following SO-239 Assemblies have wires pre-formed to fit in your KAT500. Each connector is different.

- Do not mix them up.
- Do not bend or reshape the wires.



*Ant 1 SO-239 Assembly E850553*

ILLUSTRATION	DESCRIPTION	QTY.	ELECRAFT PART NO.
	Ant 1 SO-239 Assembly	1	E850553
	4-40 Screw, 1/4" (6.4 mm) Black Pan Head	4	E700174
	4-40 Nut with Captive Star Washer	4	E700191



*Ant 2 SO-239 Assembly E850560*

ILLUSTRATION	DESCRIPTION	QTY.	ELECRAFT PART NO.
	Ant 2 SO-239 Assembly	1	E850560
	4-40 Screw, 1/4" (6.4 mm) Black Pan Head	4	E700174
	4-40 Nut with Captive Star Washer	4	E700191

*Ant 3 SO-239 Assembly E850559*

ILLUSTRATION	DESCRIPTION	QTY.	ELECRAFT PART NO.
	Ant 3 SO-239 Assembly	1	E850559
	4-40 Screw, 1/4" (6.4 mm) Black Pan Head	4	E700174
	4-40 Nut with Captive Star Washer	4	E700191

***XMTR SO-239 Assembly E850554***

<b>ILLUSTRATION</b>	<b>DESCRIPTION</b>	<b>QTY.</b>	<b>ELECRAFT PART NO.</b>
	XMTR SO-239 Assembly	1	E850554
	4-40 Screw, 1/4" (6.4 mm) Black Pan Head	4	E700174
	4-40 Nut with Captive Star Washer	4	E700191