

ELECRAFT KTS1 WIDE-RANGE TILT STAND

Rev. G, Jan. 24, 2001

The KTS1 is a versatile tilt stand for the K1 transceiver that facilitates operation at home or in the field. Two arm lengths are provided. The short arms position the display for desk or tabletop use, while the long arms are used for ground mounting (see illustration below). The tilt-stand's 3-point mount allows the K1 to be operated on any rough surface.

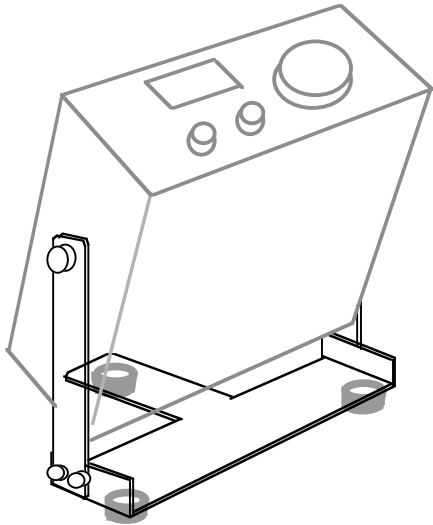

Parts Inventory

QTY	Description
1	Bracket
2	Long Arm (for ground mounting)
2	Short Arm (for desktop mounting)
3	Rubber foot
3	Hex nut, 6-32
3	#6 split lock washer
3	6-32 x 1/2" pan-head Phillips machine screw
3	10-32 Thumb screw, 1/2" long (one spare)
4	6-32 Thumb screw, 3/8" long
4	Rubber washer, 5/8" dia. x .047" , self-adhesive

Assembly

- Install rubber feet on the bottom of the bracket at each of the three points labeled "A" in the drawing at right. Use 6-32 x 1/2" pan-head screws, #6 lock washers, and 6-32 nuts.
- Install one self-adhesive rubber washer on each of the four arms. The washers should be centered over the large single holes found at one end of each arm.
- Attach either the long or short arms to the K1's side panels using 10-32 thumb screws. The rubber washers on the arms should face the K1 side panels to protect the finish.

- Attach the bracket to the two arms using 6-32 thumb screws as shown at left. If the short arms are used, the transceiver can be rested directly on the back of the bracket. If the long arms are used, adjust the transceiver for the desired viewing angle, then tighten all of the thumb screws.

NOTE: Always loosen the thumb screws before tilting the transceiver.

- The adhesive on the rubber washers should be allowed to cure overnight. For this purpose, the KTS1 should be attached to the transceiver, with the thumb screws tightened down.

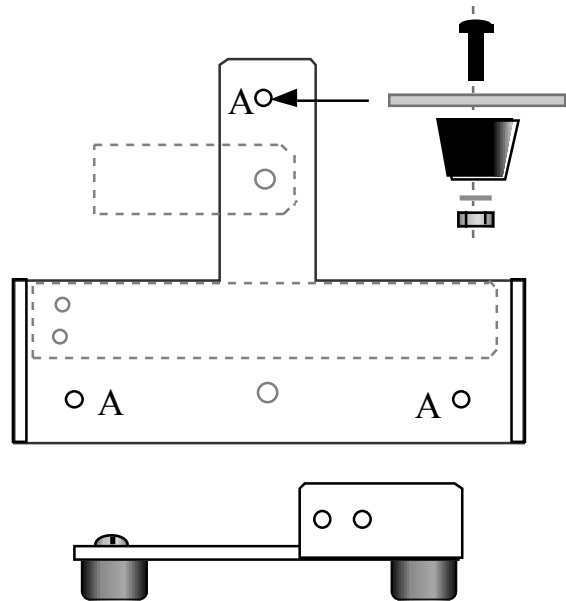

Operating Suggestions

Antenna Jack: When using the long arms, it may be helpful to use a BNC "L" adapter at the K1's antenna jack. This provides better clearance for BNC-to-banana jacks or other adapters, which are often used with field antennas.

Keyer Paddle: A lightweight keyer paddle mechanism can be attached directly to the KTS1 bracket, reducing the total weight of a portable station by eliminating the heavy keyer paddle base. The Paddlette Company's model BP-K1 is customized for use with the KTS1 (see www.paddlette.com), and can be easily adjusted for left- or right-handed use.

Transport: Both the long and short arms (indicated by the dotted lines, above) can be stacked together and attached to the bottom of the bracket. Use two 6-32 thumb screws for the long arms, and one 10-32 thumb screw for the short arms. **NOTE:** Due to product revisions, there may be small differences in the location and number of auxiliary 10-32 threaded holes in the bracket.